



# 109/166/CD

## COMMITTEE DRAFT (CD)

PROJECT NUMBER:

**IEC 60664-1 ED3**

DATE OF CIRCULATION:

**2018-02-23**

CLOSING DATE FOR COMMENTS:

**2018-05-18**

SUPERSEDES DOCUMENTS:

**109/160/CD,109/163A/CC**

### IEC TC 109 : INSULATION CO-ORDINATION FOR LOW-VOLTAGE EQUIPMENT

SECRETARIAT:

Germany

SECRETARY:

Mr Toni Hoffmann

OF INTEREST TO THE FOLLOWING COMMITTEES:

TC 2,TC 8,TC 9,TC 13,SC 17A,SC 17C,TC 22,TC 23,SC 23B,SC 23E,SC 23H,TC 28,TC 31,SC 37A,TC 38,TC 42,SC 48B,TC 61,TC 64,TC 66,TC 69,TC 70,TC 72,TC 82,TC 88,TC 91,TC 96,TC 99,TC 105,TC 108,TC 120,TC 121,SC 121A,SC 121B

PROPOSED HORIZONTAL STANDARD:

Other TC/SCs are requested to indicate their interest, if any, in this CD to the secretary.

FUNCTIONS CONCERNED:

 EMC ENVIRONMENT QUALITY ASSURANCE SAFETY

This document is still under study and subject to change. It should not be used for reference purposes.

Recipients of this document are invited to submit, with their comments, notification of any relevant patent rights of which they are aware and to provide supporting documentation.

TITLE:

**Insulation coordination for equipment within low-voltage supply systems - Part 1: Principles, requirements and tests (Proposed horizontal standard)**

NOTE FROM TC/SC OFFICERS:

## CONTENTS

1		
2		
3	FOREWORD.....	6
4	1 Scope.....	8
5	2 Normative references .....	8
6	3 Terms, definitions and abbreviations .....	9
7	3.1 Terms and definitions.....	9
8	3.2 Abbreviations.....	15
9	4 Basic technical characteristics for insulation coordination.....	15
10	4.1 General.....	15
11	4.2 Voltages .....	15
12	4.2.1 General aspects .....	15
13	4.2.2 Transient overvoltages .....	16
14	4.2.3 Temporary overvoltages .....	17
15	4.2.4 Recurring peak voltage.....	17
16	4.2.5 Steady-state working voltage.....	18
17	4.2.6 Steady-state peak voltage .....	18
18	4.3 Overvoltage categories .....	18
19	4.3.1 General .....	18
20	4.3.2 Equipment energized directly from the supply mains.....	18
21	4.3.3 Systems and equipment not energized directly from the low-voltage	
22	mains .....	18
23	4.4 Frequency.....	19
24	4.5 Pollution .....	19
25	4.5.1 General .....	19
26	4.5.2 Degrees of pollution in the micro-environment .....	19
27	4.5.3 Conditions of conductive pollution .....	19
28	4.6 Insulating material .....	19
29	4.6.1 Solid insulation, general .....	19
30	4.6.2 Stresses .....	20
31	4.6.3 Comparative tracking index (CTI) .....	21
32	4.7 Environmental aspects.....	21
33	4.7.1 General .....	21
34	4.7.2 Altitude.....	21
35	4.7.3 Temperature.....	22
36	4.7.4 Vibrations, transportation.....	22
37	4.7.5 Humidity .....	22
38	4.7.6 Duration of voltage stress.....	22
39	4.8 Field distribution .....	22
40	5 Design of insulation coordination.....	23
41	5.1 General.....	23
42	5.1.1 Design of the insulation coordination .....	23
43	5.1.2 Frequency >30 kHz.....	23
44	5.1.3 Reduced distances due to coating or potting.....	23
45	5.2 Dimensioning of clearances .....	23
46	5.2.1 General .....	23
47	5.2.2 Dimensioning criteria for clearances .....	23
48	5.2.3 Other factors involving clearances .....	24
49	5.2.4 Dimensioning of clearance of functional insulation.....	24

50	5.2.5	Dimensioning of clearances of basic insulation, supplementary insulation and reinforced insulation.....	24
51			
52	5.2.6	Isolating devices.....	25
53	5.3	Dimensioning of creepage distances.....	25
54	5.3.1	General.....	25
55	5.3.2	Dimensioning criteria of creepage distances.....	25
56	5.3.3	Other factors involving creepage distances.....	26
57	5.3.4	Dimensioning of creepage distances of functional insulation.....	28
58	5.3.5	Dimensioning of creepage distances of basic insulation, supplementary insulation and reinforced insulation.....	28
59			
60	5.4	Requirements for design of solid insulation.....	29
61	5.4.1	General.....	29
62	5.4.2	Voltage stress.....	29
63	5.4.3	Withstand of voltage stresses.....	29
64	5.4.4	Withstand on environmental stresses.....	30
65	6	Tests and measurements.....	30
66	6.1	General.....	30
67	6.2	Test for verification of clearances.....	31
68	6.2.1	General.....	31
69	6.2.2	Test voltages.....	31
70	6.3	Tests for the verification of solid insulation.....	33
71	6.3.1	General.....	33
72	6.3.2	Selection of tests.....	33
73	6.3.3	Conditioning.....	34
74	6.3.4	Impulse voltage test.....	34
75	6.3.5	AC power frequency voltage test.....	35
76	6.3.6	Partial discharge test.....	35
77	6.3.7	DC voltage test.....	37
78	6.3.8	High-frequency voltage test.....	38
79	6.4	Performing dielectric tests on complete equipment.....	38
80	6.4.1	General.....	38
81	6.4.2	Parts to be tested.....	38
82	6.4.3	Preparation of equipment circuits.....	38
83	6.4.4	Test voltage values.....	39
84	6.4.5	Test criteria.....	39
85	6.5	Other tests.....	39
86	6.5.1	Test for purposes other than insulation coordination.....	39
87	6.5.2	Sampling and routine tests.....	39
88	6.5.3	Measurement accuracy of test parameters.....	39
89	6.6	Measurement of reducing the transient voltages attenuation.....	39
90	6.7	Measurement of clearances and creepage distances.....	40
91	Annex A (informative)	Basic data on withstand characteristics of clearances.....	44
92	Annex B (informative)	Nominal voltages of supply systems for different modes of overvoltage control.....	49
93			
94	Annex C (normative)	Partial discharge test methods.....	51
95	C.1	Test circuits.....	51
96	C.1.1	General.....	51
97	C.1.2	Test circuit for earthed test specimen (Figure C.1).....	51
98	C.1.3	Test circuit for unearthed test specimen (Figure C.2).....	51
99	C.1.4	Selection criteria.....	51

100	C.1.5	Measuring impedance.....	52
101	C.1.6	Coupling capacitor $C_k$ .....	52
102	C.1.7	Filter.....	52
103	C.2	Test parameters.....	52
104	C.2.1	General .....	52
105	C.2.2	Requirements for the test voltage .....	52
106	C.2.3	Climatic conditions .....	52
107	C.3	Requirements for measuring instruments .....	52
108	C.3.1	General .....	52
109	C.3.2	Classification of PD meters.....	53
110	C.3.3	Bandwidth of the test circuit.....	53
111	C.4	Calibration .....	53
112	C.4.1	Calibration of discharge magnitude before the noise level measurement .....	53
113	C.4.2	Verification of the noise level.....	54
114	C.4.3	Calibration for the PD test .....	54
115	C.4.4	Calibration pulse generator.....	54
116	Annex D (informative)	Additional information on partial discharge test methods .....	56
117	D.1	Measurement of PD inception and extinction voltage .....	56
118	D.2	Description of PD test circuits (Figure D.1) .....	56
119	D.3	Precautions for reduction of noise .....	57
120	D.3.1	General .....	57
121	D.3.2	Sources of noise.....	57
122	D.3.3	Measures for reduction of noise.....	57
123	D.4	Application of multiplying factors for test voltages .....	57
124	D.4.1	General .....	57
125	D.4.2	Example 1 .....	57
126	D.4.3	Example 2 .....	58
127	Annex E (informative)	Comparison of creepage distances specified in Table F.5 and	
128		clearances in Table A.1 .....	59
129	Annex F (normative)	Tables .....	60
130	Annex G (informative)	Determination of clearance distances according to 5.2.....	69
131	Annex H (informative)	Determination of creepage distances according to 5.3.....	72
132	Bibliography.....		75
133			
134	Figure 1 –	Recurring peak voltage .....	17
135	Figure 2 –	Determination of the width (W) and height (H) of a rib .....	28
136	Figure 3 –	Test voltages .....	37
137	Figure A.1 –	Withstand voltage at 2 000 m above sea level .....	46
138	Figure A.2 –	Experimental data measured at approximately sea level and their low	
139		limits for inhomogeneous field.....	47
140	Figure A.3 –	Experimental data measured at approximately sea level and their low	
141		limits for homogeneous field .....	48
142	Figure C.1 –	Earthed test specimen .....	51
143	Figure C.2 –	Unearthed test specimen .....	51
144	Figure C.3 –	Calibration for earthed test specimen .....	54
145	Figure C.4 –	Calibration for unearthed test specimen.....	54
146	Figure D.1 –	Partial discharge test circuits .....	56
147	Figure E.1 –	Comparison between creepage distances specified in Table F.5 and	
148		clearances in Table A.1 .....	59

149	Figure G.1 – Determination of clearance distances according to 5.2 (continuation	
150	below).....	69
151	Figure G.1 – Determination of clearance distances according to 5.2 (continuation	
152	below).....	70
153	Figure G.1 – Determination of clearance distances according to 5.2 (end).....	71
154	Figure H.1 – Determination of creepage distances according to 5.3 (continuation	
155	below).....	72
156	Figure H.1 – Determination of creepage distances according to 5.3 (continuation).....	73
157	Figure H.1 – Determination of creepage distances according to 5.3 (end).....	74
158		
159	Table 1 – Dimensioning of grooves .....	40
160	Table A.1 – Withstand voltages in kilovolts for an altitude of 2 000 m above sea level .....	44
161	Table A.2 – Altitude correction factors for clearance correction.....	45
162	Table B.1 – Inherent control or equivalent protective control.....	49
163	Table B.2 – Cases where protective control is necessary and control is provided by	
164	surge protective device having a ratio of voltage protection level to rated voltage not	
165	smaller than that specified by IEC 61643 series.....	50
166	Table F.1 – Rated impulse withstand voltage for equipment energized directly from the	
167	low-voltage mains .....	60
168	Table F.2 – Clearances to withstand transient overvoltages.....	61
169	Table F.3 – Single-phase three or two-wire AC. or DC systems .....	62
170	Table F.4 – Three-phase four or three-wire AC systems .....	63
171	Table F.5 – Creepage distances to avoid failure due to tracking .....	64
172	Table F.6 – Test voltages for verifying clearances at different altitudes.....	66
173	Table F.7 – Severities for conditioning of solid insulation .....	66
174	Table F.8 – Clearances to withstand steady-state peak voltages, temporary	
175	overvoltages or recurring peak voltages.....	67
176	Table F.8a – Dimensioning of clearances to withstand steady-state peak voltages,	
177	temporary overvoltages or recurring peak voltages .....	67
178	Table F.8b – Additional information concerning the dimensioning of clearances to	
179	avoid partial discharge.....	67
180	Table F.9 – Altitude correction factors.....	68
181		
182		

183  
184  
185  
186  
187  
188  
189  
190  
191

# INTERNATIONAL ELECTROTECHNICAL COMMISSION

## INSULATION COORDINATION FOR EQUIPMENT WITHIN LOW-VOLTAGE SUPPLY SYSTEMS –

### Part 1: Principles, requirements and tests

#### FOREWORD

192  
193  
194  
195  
196  
197  
198  
199  
200  
201  
202  
203  
204  
205  
206  
207  
208  
209  
210  
211  
212  
213  
214  
215  
216  
217  
218  
219  
220  
221  
222  
223  
224  
225

- 1) The International Electrotechnical Commission (IEC) is a worldwide organization for standardization comprising all national electrotechnical committees (IEC National Committees). The object of IEC is to promote international co-operation on all questions concerning standardization in the electrical and electronic fields. To this end and in addition to other activities, IEC publishes International Standards, Technical Specifications, Technical Reports, Publicly Available Specifications (PAS) and Guides (hereafter referred to as "IEC Publication(s)"). Their preparation is entrusted to technical committees; any IEC National Committee interested in the subject dealt with may participate in this preparatory work. International, governmental and non-governmental organizations liaising with the IEC also participate in this preparation. IEC collaborates closely with the International Organization for Standardization (ISO) in accordance with conditions determined by agreement between the two organizations.
- 2) The formal decisions or agreements of IEC on technical matters express, as nearly as possible, an international consensus of opinion on the relevant subjects since each technical committee has representation from all interested IEC National Committees.
- 3) IEC Publications have the form of recommendations for international use and are accepted by IEC National Committees in that sense. While all reasonable efforts are made to ensure that the technical content of IEC Publications is accurate, IEC cannot be held responsible for the way in which they are used or for any misinterpretation by any end user.
- 4) In order to promote international uniformity, IEC National Committees undertake to apply IEC Publications transparently to the maximum extent possible in their national and regional publications. Any divergence between any IEC Publication and the corresponding national or regional publication shall be clearly indicated in the latter.
- 5) IEC itself does not provide any attestation of conformity. Independent certification bodies provide conformity assessment services and, in some areas, access to IEC marks of conformity. IEC is not responsible for any services carried out by independent certification bodies.
- 6) All users should ensure that they have the latest edition of this publication.
- 7) No liability shall attach to IEC or its directors, employees, servants or agents including individual experts and members of its technical committees and IEC National Committees for any personal injury, property damage or other damage of any nature whatsoever, whether direct or indirect, or for costs (including legal fees) and expenses arising out of the publication, use of, or reliance upon, this IEC Publication or any other IEC Publications.
- 8) Attention is drawn to the Normative references cited in this publication. Use of the referenced publications is indispensable for the correct application of this publication.
- 9) Attention is drawn to the possibility that some of the elements of this IEC Publication may be the subject of patent rights. IEC shall not be held responsible for identifying any or all such patent rights.

226  
227

International Standard IEC 60664 has been prepared by IEC technical committee 109: Insulation co-ordination for low-voltage equipment.

228

The text of this standard is based on the following documents:

FDIS	Report on voting
XX/XX/FDIS	XX/XX/RVD

229  
230  
231

Full information on the voting for the approval of this standard can be found in the report on voting indicated in the above table.

232

This publication has been drafted in accordance with the ISO/IEC Directives, Part 2.

233  
234  
235

The committee has decided that the contents of this publication will remain unchanged until the stability date indicated on the IEC web site under "<http://webstore.iec.ch>" in the data related to the specific publication. At this date, the publication will be

- 236 • reconfirmed,  
 237 • withdrawn,  
 238 • replaced by a revised edition, or  
 239 • amended.

240

241 The National Committees are requested to note that for this publication the stability date  
 242 is ....

243 THIS TEXT IS INCLUDED FOR THE INFORMATION OF THE NATIONAL COMMITTEES AND WILL BE  
 244 DELETED AT THE PUBLICATION STAGE.

245

**IMPORTANT – The “colour inside” logo on the cover page of this publication indicates that it contains colours which are considered to be useful for the correct understanding of its contents. Users should therefore print this publication using a colour printer.**

246

247 Informations regarding this working document:

- 248 – No major technical change compares to the previous edition IEC 60664-1 Ed2,  
 249 – Scope, Clauses 2 and 3 have been updated from IEC 60664-1 Ed2,  
 250 – Addition of 1 500 V DC into tables,  
 251 – Clauses 4 and 5 are based on a new structure,  
 252 – Annex G for clearances is added,  
 253 – Annex H for creepage distances is added,  
 254 – Automatic cross references added,  
 255 – Defined terms written in bold letters throughout the document,  
 256 – Technical countries committees are invited to have a view to try to valid values to  
 257 Table F.9. Value 0,884 seems to be in line with other standards and more logical if you  
 258 have a look to the curve below:

259

Altitude m	Factor $k_d$ for distance correction	Factor $k_d$ for distance correction
0	0,784	0,784
200	0,803	0,803
500	0,833	0,833
1 000	0,844	<b>0,884</b>
2 000	1	1

260

261



## 262 1 Scope

263 This part of IEC 60664 deals with **insulation coordination** for equipment having a  
264 **rated voltage** up to AC 1 000 V or a **rated voltage** up to DC 1 500 V connected to **low-**  
265 **voltage supply systems**.

266 This document applies to frequencies up to 30 kHz.

267 NOTE 1 **Insulation coordination** for equipment within low-voltage supply systems with rated frequencies above  
268 30 kHz is given in IEC 60664-4.

269 NOTE 2 Higher voltages can exist in internal circuits of the equipment.

270 It applies to equipment for use up to 2 000 m above sea level, and provides guidance for use  
271 at higher altitudes.

272 It provides requirements for technical committees to determine **clearances, creepage**  
273 **distances** and criteria for **solid insulation**. It includes methods of electric **testing** with  
274 respect to **insulation coordination**.

275 The minimum **clearances** specified in this document do not apply where ionized gases occur.  
276 Special requirements for such situations can be specified at the discretion of the relevant  
277 technical committee.

278 This document does not deal with distances:

- 279 – through liquid **insulation**;
- 280 – through gases other than air;
- 281 – through compressed air.

282 This document is primarily intended for use by technical committees in the preparation of  
283 standards in accordance with the principles laid down in IEC Guide 104 and  
284 ISO/IEC Guide 51. However, in case of missing specified values for clearances, creepage  
285 distances and requirements for solid insulation in the relevant product standards, or even  
286 missing standards, this document can be used.

287 One of the responsibilities of a technical committee is, wherever applicable, to make use of  
288 basic safety publications in the preparation of its publications. The requirements, **test**  
289 methods or **test** conditions of this basic safety publication will not apply unless specifically  
290 referred to or included in the relevant publications.

## 291 2 Normative references

292 The following documents are referred to in the text in such a way that some or all of their  
293 content constitutes requirements of this document. For dated references, only the edition  
294 cited applies. For undated references, the latest edition of the referenced document (including  
295 any amendments) applies.

296 IEC 60038:2009, *IEC standard voltages*

297 IEC 60068-1:2013, *Environmental testing – Part 1: General and guidance*

298 IEC 60068-2-2:2007, *Environmental testing – Part 2: Tests – Tests B: Dry heat*

299 IEC 60068-2-14:2009, *Environmental testing – Part 2-14: Tests – Test N: Change of*  
300 *temperature*

301 IEC 60068-2-78:2012, *Environmental testing – Part 2-78: Tests – Test Cab: Damp heat,*  
302 *steady state*

303 IEC 60085:2007, *Electrical insulation – Thermal evaluation and designation*

304 IEC 60099-1:1991, *Surge arresters – Part 1: Non-linear resistor type gapped surge arresters*  
305 *for a.c. systems*

---

<sup>1</sup> IEC 60099-1 has been withdrawn

306 IEC 60112:2003, Method for the determination of the proof and the comparative tracking  
307 indices of solid insulating materials  
308 IEC 60112:2003/AMD1:2009

309 IEC 60216, (all parts) *Electrical insulating materials – Thermal endurance properties*

310 IEC 60270:2000, *High-voltage test techniques – Partial discharge measurements*

311 IEC 60664-3:2016, *Insulation coordination for equipment within low-voltage systems – Part 3:*  
312 *Use of coating, potting or moulding for protection against pollution*

313 IEC 60664-4:2005, *Insulation coordination for equipment within low-voltage systems – Part 4:*  
314 *Consideration of high-frequency voltage stress*

315 IEC 60364-4-44:2007, *Low-voltage electrical installations – Part 4-44: Protection for safety –*  
316 *Protection against voltage disturbances and electromagnetic disturbances*

317 IEC 61000-4-5:2014, *Electromagnetic compatibility (EMC) - Part 4-5: Testing and*  
318 *measurement techniques - Surge immunity test*

319 IEC 61140:2016, *Protection against electric shock – Common aspects for installation and*  
320 *equipment*

321 IEC 61180:2016, *High-voltage test techniques for low-voltage equipment –Definitions, test*  
322 *and procedure requirements*

323 IEC Guide 104:2010, *The preparation of safety publications and the use of basic safety*  
324 *publications and group safety publications*

325 ISO/IEC Guide 51:2014, *Safety aspects — Guidelines for their inclusion in standards*

### 326 **3 Terms, definitions and abbreviations**

327 For the purposes of this document, the following definitions apply.

328 ISO and IEC maintain terminological databases for use in standardization at the following  
329 addresses:

- 330 • IEC Electropedia: available at <http://www.electropedia.org/>
- 331 • ISO Online browsing platform: available at <http://www.iso.org/obp>

#### 332 **3.1 Terms and definitions**

##### 333 **3.1.1**

##### 334 **low-voltage supply system**

335 all installations and plant provided for the purpose of generating, transmitting and distributing  
336 electricity

337 [SOURCE: IEC 60050-601:1985, 601-01-01, modified – Title “low-voltage supply system”  
338 instead of “electric power system – electricity supply system”]

##### 339 **3.1.2**

##### 340 **insulation coordination**

341 mutual correlation of **insulation** characteristics of electrical equipment taking into account the  
342 expected **micro-environment** and other influencing stresses

343 Note 1 to entry: Expected voltage stresses are characterized in terms of the characteristics defined in 3.1.6  
344 to 3.1.17.

345 [SOURCE: IEC 60050-442:1998/AMD1:2015, 442-09-01, modified – “electrical” instead of  
346 “electric” and Note 1 to entry has been added]

##### 347 **3.1.3**

##### 348 **clearance**

349 shortest distance in air between two conductive parts

350 Note 1 to entry: This distance can be measured along a string stretched the shortest way between these  
351 conductive parts.

352 [SOURCE: IEC 60050-501:2000, 501-07-70, modified – Note 1 to entry has been added]

353 **3.1.4**354 **creepage distance**

355 shortest distance along the surface of a solid insulating material between two conductive  
356 parts

357 [SOURCE: IEC 60050-151:2001, 151-15-50]

358 **3.1.5**359 **solid insulation**

360 solid insulating material or a combination of solid insulating materials, placed between two  
361 conductive parts or between a conductive part and a body part

362 [SOURCE: IEC 60050-903:2015, 903-04-14, modified – without the example]

363 **3.1.6**364 **working voltage**

365 highest r.m.s. value of the AC or DC voltage across any particular **insulation** which can occur  
366 when the equipment is supplied at **rated voltage**

367 Note 1 to entry: **Transient overvoltages** are disregarded.

368 Note 2 to entry: Both open-circuit conditions and normal operating conditions are taken into account.

369 [SOURCE: IEC 60050-851:2008, 851-12-31]

370 **3.1.7**371 **steady-state working voltage**

372 working voltage after the transient voltage phenomena have subsided

373 **3.1.8**374 **steady-state peak voltage**

375 peak value of the **steady-state voltage**

376 **3.1.9**377 **recurring peak voltage**

378  $U_{rp}$

379 maximum peak value of periodic excursions of the voltage waveform resulting from distortions  
380 of an AC voltage or from AC components superimposed on a DC voltage

381 [SOURCE: IEC 60050-442:1998/AMD1:2015, 442-09-15, modified – Note 1 to entry has been  
382 deleted]

383 **3.1.10**384 **overvoltage**

385 any voltage having a peak value exceeding the corresponding peak value of maximum  
386 **steady-state voltage** at normal operating conditions

387 **3.1.11**388 **temporary overvoltage**

389 **overvoltage** at power frequency of relatively long duration

390 [SOURCE: IEC 60050-614:2016, 614-03-13, modified – “overvoltage at power frequency”  
391 instead of “power frequency overvoltage” and Note 1 to entry has been deleted]

392 **3.1.12**393 **transient overvoltage**

394 short duration **overvoltage** of a few milliseconds or less, oscillatory or non-oscillatory, usually  
395 highly damped

396 [SOURCE: IEC 60050-614:2016, 614-03-14, modified – “short duration overvoltage” instead of  
397 “overvoltage with a duration” and Note 1 to entry and Note 2 to entry have been deleted]

398 **3.1.13**399 **withstand voltage**

400 voltage to be applied to a specimen under prescribed **test** conditions which does not cause  
401 breakdown and/or **flashover** of a satisfactory specimen

402 **3.1.14**  
403 **impulse withstand voltage**  
404 highest peak value of impulse voltage of prescribed form and polarity which does not cause  
405 breakdown of **insulation** under specified conditions

406 [SOURCE: IEC 60050-442:1998/AMD1:2015, 442-09-18]

407 **3.1.15**  
408 **r.m.s. withstand voltage**  
409 r.m.s. value of sinusoidal power frequency voltage that the equipment can withstand during  
410 tests made under specified conditions and for a specified duration

411 [SOURCE: IEC 60050-581:2008, 581-21-21]

412 **3.1.16**  
413 **recurring peak withstand voltage**  
414 highest peak value of a recurring voltage which does not cause breakdown of **insulation**  
415 under specified conditions

416 [SOURCE: IEC 60050-442:1998/AMD1:2015, 442-09-20]

417 **3.1.17**  
418 **temporary withstand overvoltage**  
419 highest r.m.s value of a temporary **overvoltage** which does not cause breakdown of  
420 **insulation** under specified conditions

421 [SOURCE: IEC 60050-442:1998/AMD1:2015, 442-09-19]

422 **3.1.18**  
423 **rated voltage**  
424  $U_n$   
425 value of voltage assigned by the manufacturer, to a component, device or equipment and to  
426 which operation and performance characteristics are referred

427 Note 1 to entry: Equipment may have more than one **rated voltage** value or may have a **rated voltage** range.

428 [SOURCE: IEC 60050-442:1998/AMD1:2015, 442-09-10, modified – “value of voltage” instead  
429 of “rated value of the voltage” and Note 2 to entry has been deleted]

430 **3.1.19**  
431 **rated insulation voltage**  
432  $U_i$   
433 value of the rms withstand voltage assigned by the manufacturer to the equipment or to a part  
434 of it, characterizing the specified (long-term) withstand capability of its **insulation**

435 Note 1 to entry: The **rated insulation voltage** is equal to or greater than the **rated voltage** of equipment which is  
436 primarily related to functional performance.

437 [SOURCE: IEC 60050-312:2015, 312-06-02, modified – “rated value” has been replaced by  
438 “value”]

439 **3.1.20**  
440 **rated impulse withstand voltage**  
441  $U_{imp}$   
442 **impulse withstand voltage** value assigned by the manufacturer to the equipment or to a part  
443 of it, characterizing the specified withstand capability of its **insulation** against **transient**  
444 **overvoltages**

445 **3.1.21**  
446 **rated temporary withstand overvoltage**  
447 **temporary withstand overvoltage** value assigned by the manufacturer to the equipment, or  
448 to a part of it, characterizing the specified short-term withstand capability of its **insulation**  
449 against AC voltages

450 **3.1.22**  
451 **overvoltage category**  
452 numeral defining a **transient overvoltage** condition

453 Note 1 to entry: **Overvoltage categories I, II, III and IV** are used, see 4.3.2.

454 [SOURCE: IEC 60050-581:2008, 581-21-02, modified – Note 1 to entry has been added]

### 455 **3.1.23**

#### 456 **environment**

457 surrounding which may affect performance of a device or system

458 Note 1 to entry: Examples are pressure, temperature, humidity, **pollution**, radiation and vibration.

### 459 **3.1.24**

#### 460 **macro-environment**

461 **environment** of the room or other location in which the equipment is installed or used

462 [SOURCE: IEC 60050-442:1998/AMD1:2015, 442-01-55]

### 463 **3.1.25**

#### 464 **micro-environment**

465 immediate **environment** of the **insulation** which particularly influences the dimensioning of  
466 the **creepage distances**

467 [SOURCE: IEC 60050-851:2008, 851-15-16]

### 468 **3.1.26**

#### 469 **pollution**

470 any condition of foreign matter, solid, liquid or gaseous (ionized gases), that may affect  
471 dielectric strength or surface resistivity

### 472 **3.1.27**

#### 473 **pollution degree**

474 numeral characterizing the expected **pollution** of the **micro-environment**

475 [SOURCE: IEC 60050-581:2008, 581-21-07, modified – Note 1 to entry has been deleted]

### 476 **3.1.28**

#### 477 **homogeneous field**

478 electric field which has an essentially constant voltage gradient between electrodes

479 Note 1 to entry: The **homogeneous field** condition is referred to as case B in Table F.2 and Table F.8a.

### 480 **3.1.29**

#### 481 **inhomogeneous field**

482 electric field which does not have an essentially constant voltage gradient between electrodes  
483 (non-uniform field)

484 [SOURCE: IEC 60050-442:1998/AMD1:2015, 442-09-03, modified – “inhomogeneous field”  
485 instead of “inhomogeneous electric field” and Note 1 to entry and Note 2 to entry have been  
486 deleted]

### 487 **3.1.30**

#### 488 **Insulation**

489 that part of an electrotechnical product which separates the conducting parts at different  
490 electrical potentials during operation or insulates such parts from the surroundings

491 [SOURCE: IEC 60050-212:2010, 212-11-07, modified – title without “electric” and “that part”  
492 instead of “part”]

### 493 **3.1.31**

#### 494 **functional insulation**

495 insulation between conductive parts which is necessary only for the proper functioning of the  
496 equipment

### 497 **3.1.32**

#### 498 **basic insulation**

499 **insulation** of hazardous-live-parts which provides basic protection

500 Note 1 to entry: This concept does not apply to insulation used exclusively for functional purposes.

501 [SOURCE: IEC 60050-826:2004, 826-12-14]

502 **3.1.33**  
503 **supplementary insulation**  
504 independent **insulation** applied in addition to **basic insulation** for fault protection

505 [SOURCE: IEC 60050-826:2004, 826-12-15]

506 **3.1.34**  
507 **double insulation**  
508 **insulation** comprising both **basic insulation** and **supplementary insulation**

509 [SOURCE: IEC 60050-826:2004, 826-12-16]

510 **3.1.35**  
511 **reinforced insulation**  
512 **insulation** of hazardous-live-parts which provides a degree of protection against electric  
513 shock equivalent to **double insulation**

514 Note 1 to entry: **Reinforced insulation** may comprise several layers which cannot be tested singly as **basic**  
515 **insulation** or **supplementary insulation**.

516 [SOURCE: IEC 60050-826:2004, 826-12-17]

517 **3.1.36**  
518 **partial discharge**  
519 **PD**  
520 electric discharge that partially bridges the **insulation**

521 Note 1 to entry: A **partial discharge** may occur inside the **insulation** or adjacent to a conductor.

522 Note 2 to entry: Scintillations of low energy on the surface of insulating materials are often described as **partial**  
523 **discharges** but should rather be considered as disruptive discharges of low energy, since they are the result of  
524 local dielectric breakdowns of high ionization density, or small arcs, according to the conventions of physics.

525 [SOURCE: IEC 60050-442:1998/AMD1:2015, 442-09-05, modified – Notes 1 to entry and Note  
526 2 to entry have been added]

527 **3.1.37**  
528 **apparent charge**  
529  $q_{app}$   
530 electric charge which can be measured at the terminals of the specimen under **test**

531 Note 1 to entry: The **apparent charge** is smaller than the **partial discharge**.

532 Note 2 to entry: The measurement of the **apparent charge** requires a short-circuit condition at the terminals of  
533 the specimen (see Clause D.2) under **test**.

534 [SOURCE: IEC 60050-442:1998/AMD1:2015, 442-09-06, modified – In the Note 2 to entry,  
535 “(see Clause D.2)” has been added]

536 **3.1.38**  
537 **specified discharge magnitude**  
538 magnitude of the **apparent charge** which is regarded as the limiting value according to the  
539 objective of this document

540 Note 1 to entry: The pulse with the maximum amplitude should be evaluated.

541 Note 2 to entry: Adapted to be in accordance with the objective of this document.

542 [SOURCE: IEC 60050-442:1998/AMD1;2015, 442-09-07, modified – “which” instead of “when  
543 this”, introduction of “according to the objective of this document” and Note 2 to entry has  
544 been added]

545 **3.1.39**  
546 **pulse repetition rate**  
547 average number of pulses per second with an **apparent charge** higher than the detection  
548 level

549 Note 1 to entry: Within the scope of this document, it is not permitted to weigh discharge magnitudes according to  
550 the **pulse repetition rate**.

551 **3.1.40**552 **partial discharge inception voltage**553  **$PDU_i$** 

554 lowest peak value of the **test** voltage at which the **apparent charge** becomes greater than the  
555 **specified discharge magnitude** when the **test** voltage is increased above a low value for  
556 which no discharge occurs

557 Note 1 to entry: For AC **tests** the r.m.s. value may be used.

558 [SOURCE: IEC 60050-212 2015/AMD1, 212-11-41]

559 **3.1.41**560 **partial discharge extinction voltage**561  **$PDU_e$** 

562 lowest peak value of the **test** voltage at which the **apparent charge** becomes less than the  
563 **specified discharge magnitude** when the **test** voltage is reduced below a high level where  
564 such discharges have occurred

565 Note 1 to entry: For AC **tests** the r.m.s. value may be used.

566 **3.1.42**567 **partial discharge test voltage**568  **$PDU_t$** 

569 peak value of the voltage in a partial discharge test, where the **apparent charge** is less than  
570 the **specified discharge magnitude**

571 Note 1 to entry: For AC **tests** the r.m.s. value may be used.

572 [SOURCE: IEC 60050-212:2014, 212-11-62, modified – Note 1 to entry has been deleted,  
573 Note 2 to entry is renumbered as Note 1 to entry]

574 **3.1.43**575 **test**

576 technical operation that consists of the determination of one or more characteristics of a given  
577 product, process or service according to a specified procedure

578 Note 1 to entry: A **test** is carried out to measure or classify a characteristic or a property of an item by applying to  
579 the item a set of environmental and operating conditions and/or requirements.

580 [SOURCE: IEC 60050-151:2001, 151-16-13]

581 **3.1.44**582 **type test**

583 **test** made on one or more devices representative to a certain design to check the conformity  
584 to the specifications

585 **3.1.45**586 **routine test**

587 conformity **test** made on each individual item during or after manufacture

588 [SOURCE: IEC 60050-151:2001, 151-16-17]"

589 **3.1.46**590 **sampling test**

591 **test** on a number of devices taken at random from a batch

592 [SOURCE: IEC 60050-811:1991, 811-10-06]

593 **3.1.47**594 **electrical breakdown**

595 failure of **insulation** under electric stress when the discharge completely bridges the  
596 **insulation**, thus reducing the voltage between the electrodes almost to zero

597 **3.1.48**598 **sparkover**

599 **electrical breakdown** in a gaseous or liquid medium

600 **3.1.49**601 **flashover**

602 **electric breakdown** between conductors in a gas or a liquid or in vacuum, at least partly  
603 along the surface of **solid insulation**

604 **3.1.50**605 **puncture**

606 **electrical breakdown** through **solid insulation**

607 [SOURCE: IEC 60050-614:2016, 614-03-17, modified – “electrical breakdown” instead of  
608 “disruptive discharge” and “insulation” instead of “dielectric”]

609 **3.2 Abbreviations**

610 Alphabetical list of terms with abbreviations together with the subclause where they are first  
611 used:

Abbreviations	Term	Subclause
$U_n$	rated voltage	3.1.18
$U_i$	rated insulation voltage	3.1.19
$U_{imp}$	rated impulse withstand voltage	3.1.20
$U_{rp}$	recurring peak voltage	3.1.9
$q_{app}$	apparent charge	3.1.37
PD	partial discharge	3.1.36
$PDU_i$	partial discharge inception voltage	3.1.40
$PDU_e$	partial discharge extinction voltage	3.1.41
$PDU_t$	partial discharge test voltage	3.1.42

612

613 **4 Basic technical characteristics for insulation coordination**614 **4.1 General**

615 **Insulation coordination** requires the selection of the electric **insulation** technical  
616 characteristics of the equipment with regard to its application and in relation to its  
617 surroundings. It represents one aspect of the safety of persons, livestock and property, so  
618 that the probability of undesired incidents due to voltage stresses does not lead to an  
619 unacceptable risk of harm.

620 NOTE See ISO/IEC Guide 51 and IEC Guide 116 for further details about risk assessment and unacceptable risk  
621 of harm.

622 Electric **insulation** technical characteristics cover:

- 623 – voltages across the **insulation** according to 4.2
- 624 – **overvoltage categories** according to 4.3;
- 625 – frequency according to 4.4;
- 626 – **pollution degree** according to 4.5;
- 627 – **insulation** materials according to 4.6; and
- 628 – environmental aspects according to 4.7 (e.g. temperature, altitude, vibrations, humidity,  
629 duration);
- 630 – field distribution according to 4.8.

631 **Insulation coordination** can only be achieved if the design of the equipment is based on the  
632 stresses to which it is likely to be subjected during its intended life.

633 **4.2 Voltages**634 **4.2.1 General aspects**

635 When considering **insulation** performances, the following aspects are relevant:

- 636 – the voltages which can appear within the system:
- 637 • **transient overvoltages** and **overvoltage category** according to 4.2.2;
  - 638 • **temporary overvoltages** according to 4.2.3.
- 639 – the voltages generated by the equipment (which could adversely affect other equipment in
- 640 the system):
- 641 • **recurring peak voltage** according to 4.2.4;
  - 642 • **steady-state working voltage** according to 4.2.5;
  - 643 • **steady-state peak voltage** according to 4.2.6.

## 644 4.2.2 Transient overvoltages

### 645 4.2.2.1 General

646 To apply the concept of **insulation coordination**, **transient overvoltage** shall be taken into

647 consideration. The **transient overvoltages** that shall be considered are:

- 648 – **transient overvoltages** generated by atmospheric disturbances (for example indirect
- 649 lightning strikes) and transmitted by the supply distribution system;
- 650 – **transient overvoltages** generated due to switching of loads in the supply system;
- 651 – **transient overvoltages** generated by external circuits; and
- 652 – **transient overvoltages** generated internally in the equipment.

653 **Insulation coordination** uses a preferred series of values of impulse voltages. The preferred

654 values of rated impulse withstand voltage are:

655 330 V, 500 V, 800 V, 1 500 V, 2 500 V, 4 000 V, 6 000 V, 8 000 V, 12 000 V.

### 656 4.2.2.2 Transient overvoltages entering through the mains

657 To determine the expected transients generated by atmospheric disturbances or due to

658 switching of loads in the supply system, the **rated voltage** ( $U_n$ ) and the **overvoltage category**

659 are normally used as the basis to determine the required impulse withstand voltage.

660 For equipment that is likely, when installed, to be subjected to transient voltages that exceed

661 those of the **overvoltage category** typically defined for such kind of equipment, these

662 transient voltages shall be taken into account.

### 663 4.2.2.3 Transient overvoltages generated by external circuits

664 The applicable value of the transient voltage that may occur on any external circuit (for

665 example coax or twisted pair networks) shall be determined. Where more than one external

666 circuit is present, the highest transient voltage applies.

667 If the external circuit transient voltages are known to be higher than the one from the

668 **overvoltage category** typically defined for such kind of equipment, the highest value of these

669 known transient voltages shall be used.

### 670 4.2.2.4 Transient overvoltages generated internally in the equipment

671 For the equipment capable of generating an **overvoltage** that is higher than the transients

672 expected to come in to the equipment, for example due to switching devices, the required

673 impulse voltage shall take into account the transient generated in the equipment.

### 674 4.2.2.5 Attenuation of transient voltage levels

675 Equipment or parts of equipment may be used under conditions where the transients are

676 reduced. For example, attenuation of the transient can occur due to:

- 677 – an **overvoltage** protective device;

678 NOTE SPD, in some applications, can allow voltage coordination between devices installed and using different

679 performances regarding their overvoltage category.

- 680 – a transformer with isolated windings, where the secondary winding is earthed, or a
- 681 transformer employing an earth screen between primary and secondary or any kind of
- 682 attenuation system coupling with transformer;

- 683 – a distribution system with a multiplicity of branch circuits capable of diverting energy of
- 684 surges;

- 685 – a capacitance capable of absorbing energy of surges; or  
 686 – a resistance or similar damping device capable of dissipating the energy of surges.

687 Attention is drawn to the fact that an **overvoltage** protective device within the installation or  
 688 within equipment may have to dissipate more energy than an **overvoltage** protective device  
 689 at the origin of the installation having a higher protection level (clamping voltage). This  
 690 applies particularly to the **overvoltage** protective device with the lowest protection level  
 691 (clamping voltage).

692 In case attenuation of the transient is expected, the transient voltage across the **insulation**  
 693 may be measured by applying the required impulse **test** to the equipment and measuring the  
 694 actual remaining transient over the **insulation**. The measured value may be used as the  
 695 expected transient voltage. While performing the **test**, transients of both polarities shall be  
 696 considered.

#### 697 4.2.3 Temporary overvoltages

698 Due to faults on the public mains distribution system **temporary overvoltages** between lines  
 699 and earth/neutral of several seconds will be generated and shall be considered when applying  
 700 the concept of **insulation coordination**.

701 **Insulation coordination** with regard to **temporary overvoltages** is based on the **temporary**  
 702 **overvoltage** specified in Clause 442 of IEC 60364-4-44: 2007. The values of **temporary**  
 703 **overvoltage** in low-voltage equipment due to an earth fault in the high-voltage system are  
 704 given in 5.4.3.2.

#### 705 4.2.4 Recurring peak voltage

706 Due to the intended operation modes of specific products, internally generated voltages may  
 707 also include recurring peaks superimposed to the **working voltage**. These recurring peaks  
 708 voltages shall be considered when applying the concept of **insulation coordination**.

709 **Insulation coordination** with regard to **recurring peak voltage** shall consider that **partial**  
 710 **discharges** can occur in **solid insulation** (see 4.6.2.3) or along surfaces of **insulation** (see  
 711 Table F.8b).

712 NOTE See 4.4.2 and Table 1 of IEC/TS 61934:2011 for an example of parameter values of characteristics of  
 713 **partial discharge** measurement.

714 **Recurring peak voltage** has a waveshape which is measured by an oscilloscope of sufficient  
 715 bandwidth, from which the peak amplitude is determined according to Figure 1.

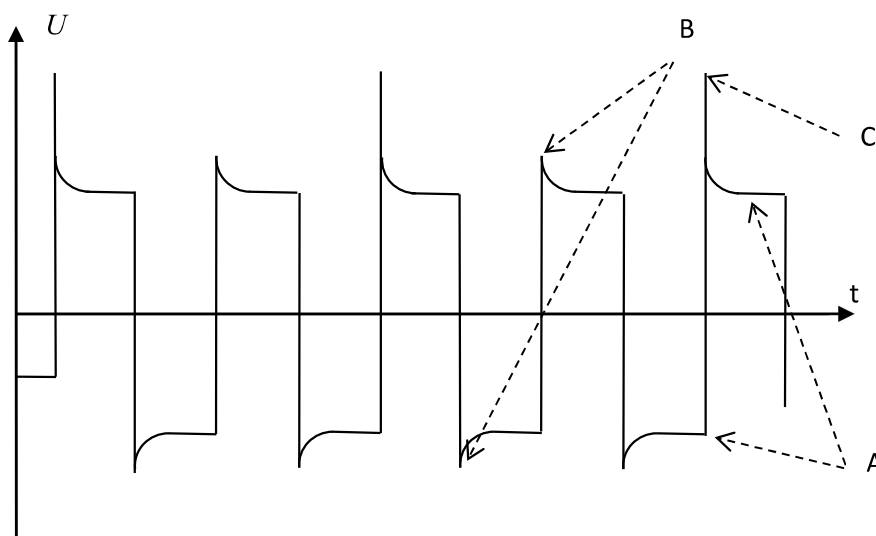

716

717 **Key**

718 A Steady-state working voltage value, (e.g as normal working voltage)

719 B Peak of the working value

720 C Recurring peak voltage

721

**Figure 1 – Recurring peak voltage**

#### 722 4.2.5 Steady-state working voltage

723 The highest **steady-state working voltage** (RMS value of the AC or DC value) across the  
724 insulation with the equipment supplied at the **rated voltage** shall be considered. This kind of  
725 **steady-state voltage** can be lower, equal or higher than the **rated voltage** of the equipment.  
726 The **steady-state working voltage** of internal circuits is a direct consequence of the design  
727 of products.

#### 728 4.2.6 Steady-state peak voltage

729 The highest continuous **peak voltage** across the insulation with the equipment supplied at the  
730 **rated voltage** shall be considered. The **steady-state peak voltage** of internal circuits is a  
731 direct consequence of the design of products.

### 732 4.3 Overvoltage categories

#### 733 4.3.1 General

734 The concept of **overvoltage categories** is used for equipment energized directly from the  
735 low-voltage mains.

736 The **overvoltage categories** have a probabilistic implication rather than the meaning of  
737 physical attenuation of the **transient overvoltage** downstream in the installation.

738 NOTE This concept of **overvoltage categories** is used in Clause 443 of IEC 60364-4-44:2007.

739 A similar concept can also be used for equipment connected to other systems, for example  
740 telecommunication and data systems.

#### 741 4.3.2 Equipment energized directly from the supply mains

742 Technical committees shall specify the **overvoltage category** as based on the following  
743 general explanation of **overvoltage categories**:

744 – Equipment with an impulse withstand voltage corresponding to overvoltage category IV is  
745 suitable for use at, or in the proximity of, the origin of the installation, for example  
746 upstream of the main distribution board. Equipment of category IV has a very high impulse  
747 withstand capability providing the required high degree of reliability.

748 NOTE 1 Examples of such equipment are electricity meters, primary overcurrent protection devices and ripple  
749 control units.

750 – Equipment with an impulse withstand voltage corresponding to overvoltage category III is  
751 for use in the fixed installation downstream of, and including the main distribution board,  
752 providing a high degree of availability.

753 NOTE 2 Examples of such equipment are distribution boards, circuit-breakers, wiring systems (see IEC 60050-  
754 826, definition 826-15-01), including cables, bus-bars, junction boxes, switches, socket-outlets) in the fixed  
755 installation, and equipment for industrial use and some other equipment, e.g. stationary motors with permanent  
756 connection to the fixed installation.

757 – Equipment with an impulse withstand voltage corresponding to overvoltage category II is  
758 suitable for connection to the fixed electrical installation, providing a normal degree of  
759 availability normally required for current-using equipment.

760 NOTE 3 Examples of such equipment are household appliances and similar loads.

761 – Equipment with an impulse withstand voltage corresponding to overvoltage category I is  
762 only suitable for use in the fixed installation of buildings where protective means are  
763 applied outside the equipment – to limit transient overvoltages to the specified level.

764 NOTE 4 Examples of such equipment are those containing electronic circuits like computers, appliances with  
765 electronic programmes, etc.

766 – Equipment with an impulse withstand voltage corresponding to overvoltage category I  
767 shall not have direct connection to a public supply system.

#### 768 4.3.3 Systems and equipment not energized directly from the low-voltage mains

769 It is recommended that technical committees specify **overvoltage categories** or **rated**  
770 **impulse withstand voltage** as appropriate. Application of the preferred series of 4.2.2.1 is  
771 recommended.

772 NOTE Telecommunication or industrial control systems or independent systems on vehicles are examples of such  
773 systems.

#### 774 4.4 Frequency

775 For frequencies above 1 kHz additional or alternative AC voltage **tests** according to 6.3.5 or  
776 **partial discharge tests** according to 6.3.6 may be necessary. For high frequencies voltage  
777 test, see also 6.3.8.

#### 778 4.5 Pollution

##### 779 4.5.1 General

780 The **micro-environment** determines the effect of **pollution** on the **insulation**. The **macro-**  
781 **environment**, however, has to be taken into account when considering the **micro-**  
782 **environment**.

783 Means may be provided to reduce **pollution** at the **insulation** under consideration by  
784 effective use of enclosures, encapsulation or hermetic sealing. Such means to reduce  
785 **pollution** may not be effective when the equipment is subject to condensation or if, in normal  
786 operation, it generates pollutants itself.

787 Degrees of protection provided by enclosures (IP), according to the classes specified in  
788 IEC 60529, do not necessarily improve the **micro-environment** with regard to **pollution**.

789 Small **clearances** can be bridged completely by solid particles, dust and water and therefore  
790 minimum **clearances** are specified where **pollution** may be present in the **micro-**  
791 **environment**.

##### 792 4.5.2 Degrees of pollution in the micro-environment

793 For the purpose of evaluating **creepage distances** and **clearances**, the following four  
794 degrees of **pollution** in the **micro-environment** are established:

###### 795 – *Pollution degree 1*

796 No **pollution** or only dry, non-conductive **pollution** occurs. The **pollution** has no  
797 influence.

###### 798 – *Pollution degree 2*

799 Only non-conductive **pollution** occurs except that occasionally a temporary conductivity  
800 caused by condensation is to be expected. This condensation may occur during periods of  
801 on-off load cycles of the equipment.

###### 802 – *Pollution degree 3*

803 Conductive **pollution** occurs or dry non-conductive **pollution** occurs which becomes  
804 conductive due to condensation which is to be expected.

###### 805 – *Pollution degree 4*

806 Continuous conductivity occurs due to conductive dust, rain or other wet conditions.

##### 807 4.5.3 Conditions of conductive pollution

808 The dimensions for **creepage distance** cannot be specified where permanently conductive  
809 **pollution** is present (**pollution degree 4**). For temporarily conductive **pollution** (**pollution**  
810 **degree 3**), the surface of the **insulation** may be designed to avoid a continuous path of  
811 conductive **pollution**, e.g. by means of ribs and grooves (see 5.3.3.7).

#### 812 4.6 Insulating material

##### 813 4.6.1 Solid insulation, general

814 The concept of **insulation coordination** may be realized by an appropriate **insulation**  
815 material. The **insulation** behaviour of the **solid insulation** is affected by its material  
816 characteristics. Electrical, mechanical and other stresses which might affect the **insulation**  
817 behaviour over the life time of the product shall be considered.

818 As the electric strength of **solid insulation** is considerably greater than that of air, it may  
819 receive little attention during the design of low-voltage **insulation** systems. On the other  
820 hand, the insulating distances through solid insulating material are, as a rule, much smaller

821 than the **clearances** so that high electric stresses result. Another point to be considered is  
822 that the high electric strength of material is seldom made use of in practice. In **insulation**  
823 systems, gaps may occur between electrodes and **insulation** and between different layers of  
824 **insulation**, or voids may be present in the **insulation**. **Partial discharges** can occur in these  
825 gaps or voids at voltages far below the level of **puncture** and this may influence decisively  
826 the service life of the **solid insulation**. However, **partial discharges** are unlikely to occur  
827 below a peak voltage of 500 V.

828 Of equally fundamental importance is the fact that **solid insulation**, as compared with gases,  
829 is not a renewable insulating medium so that, for example, high voltage peaks which may  
830 occur infrequently can have a very damaging effect on **solid insulation**. This situation can  
831 occur while in service and during routine high-voltage **testing**.

832 A number of detrimental influences accumulate over the service life of **solid insulation**.  
833 These follow complex patterns and result in ageing. Therefore, electrical and other stresses  
834 (e.g. thermal, environmental) are superimposed and contribute to ageing.

835 The long-term performance of **solid insulation** can be simulated by a short-term **test** in  
836 combination with suitable conditioning (see 6.3.3).

837 If **solid insulation** is subjected to high frequencies, the dielectric losses of **solid insulation**  
838 and **partial discharges** become increasingly important. This condition has been observed in  
839 switched-mode power supplies where the **insulation** is subjected to repetitive voltage peaks  
840 at frequencies up to 500 kHz.

841 There is a general relationship between the thickness of **solid insulation** and the aforesaid  
842 failure mechanisms. By a reduction of the thickness of **solid insulation** the field strength is  
843 increased and leads to a higher risk of failure. As it is not possible to calculate the required  
844 thickness of **solid insulation** the performance can only be verified by **testing**.

## 845 **4.6.2 Stresses**

### 846 **4.6.2.1 Frequency of the voltage**

847 The frequency of the voltage influences the electric strength of the **solid insulation**.  
848 Dielectric heating and the probability of thermal instability increase approximately in  
849 proportion to the frequency. Increasing the frequency will reduce the electric strength of most  
850 insulating materials.

### 851 **4.6.2.2 Mechanical shock**

852 In the case of inadequate impact strength, mechanical shock may cause **insulation** failure.  
853 Failure from mechanical shock could also occur due to reduced impact strength of materials:

- 854 – due to material becoming brittle when the temperature falls below its glass transition  
855 temperature;
- 856 – after prolonged exposure to high temperature that has caused loss of plasticiser or  
857 degradation of the base polymer.

858 Technical committees shall consider this when specifying environmental conditions for  
859 transportation, storage, installation and use.

### 860 **4.6.2.3 Partial discharges (PD)**

861 Some types of **solid insulation** can withstand discharges, while others cannot. Voltage,  
862 repetition rate of discharges and discharge magnitude are important parameters.

863 NOTE Ceramic insulators are usually able to withstand **partial discharges**.

864 The PD behaviour is influenced by the frequency of the applied voltage. It is established from  
865 accelerated life **tests** at increased frequency that the time to failure is approximately inversely  
866 proportional to the frequency of the applied voltage. However, practical experience only  
867 covers frequencies up to 5 kHz since, at higher frequencies, other failure mechanisms may  
868 also be present, for example dielectric heating.

### 869 **4.6.2.4 Other stresses**

870 Many other stresses can damage **insulation** and their consequences need to be considered  
871 by technical committees

872 Examples of such stresses include:

- 873 – radiation, both ultraviolet and ionizing;
- 874 – stress-crazing or stress-cracking caused by exposure to solvents or active chemicals;
- 875 – migration of plasticizers;
- 876 – the effect of bacteria, moulds or fungi;
- 877 – mechanical creep.

#### 878 **4.6.3 Comparative tracking index (CTI)**

##### 879 **4.6.3.1 Behaviour of insulating material in the presence of scintillations**

880 With regard to tracking, an insulating material can be roughly characterized according to the  
881 damage it suffers from the concentrated release of energy during scintillations when a surface  
882 leakage current is interrupted due to the drying-out of the contaminated surface. The following  
883 behaviour of an insulating material in the presence of scintillations can occur:

- 884 – no decomposition of the insulating material;
- 885 – the wearing away of insulating material by the action of electrical discharges (electrical  
886 erosion);
- 887 – the progressive formation of conductive paths which are produced on the surface of  
888 insulating material due to the combined effects of electric stress and electrolytically  
889 conductive contamination on the surface (tracking).

890 NOTE Tracking or erosion will occur when:

- 891 – a liquid film carrying the surface leakage current breaks; and
- 892 – the applied voltage is sufficient to break down the small gap formed when the film breaks; and
- 893 – the current is above a limiting value which is necessary to provide sufficient energy locally to thermally  
894 decompose the insulating material beneath the film.

895 Deterioration increases with the time for which the current flows.

##### 896 **4.6.3.2 CTI values to categorize insulating materials**

897 A method of classification for insulating materials according to 4.6.3.1 does not exist. The  
898 behaviour of the insulating material under various contaminants and voltages is extremely  
899 complex. Under these conditions, many materials may exhibit two or even all three of the  
900 characteristics stated. A direct correlation with the material groups of 5.3.2.4 is not practical.  
901 However, it has been found by experience and **tests** that insulating materials having a higher  
902 relative performance also have approximately the same relative ranking according to the  
903 comparative tracking index (CTI). Therefore, this document uses the CTI values to categorize  
904 insulating materials.

##### 905 **4.6.3.3 Test for comparative tracking index (CTI)**

906 The **test** for comparative tracking index (CTI) in accordance with IEC 60112 is designed to  
907 compare the performance of various insulating materials under **test** conditions. It gives a  
908 qualitative comparison and in the case of insulating materials having a tendency to form  
909 tracks, it also gives a quantitative comparison.

##### 910 **4.6.3.4 Non-tracking materials**

911 For glass, ceramics or other inorganic insulating materials which do not track, creepage  
912 distances need not be greater than their associated clearance for the purpose of insulation  
913 coordination.

#### 914 **4.7 Environmental aspects**

##### 915 **4.7.1 General**

916 The physical and geographical location of the equipment can affect the **insulation** system  
917 significantly. Environmental factors as altitude, temperature, vibrations and humidity require  
918 consideration to ensure that the **insulation coordination** remains reliable over the life time of  
919 the equipment.

##### 920 **4.7.2 Altitude**

921 The breakdown voltage of a clearance in air is, according to Paschen's Law, proportional to  
922 the product of the distance between electrodes and the atmospheric pressure. The required

923 distances for clearance in this standard is corrected according to the difference in  
924 atmospheric pressure between 2 000 m and sea level for homogeneous inhomogeneous  
925 fields.

926 See 5.2.3.4 for dimensioning of clearance for altitude above 2 000 m and 6.2.2.1.4 for altitude  
927 consideration when verifying clearance at altitude different from 2 000 m.

#### 928 **4.7.3 Temperature**

929 Temperature can cause:

- 930 – mechanical distortion due to the release of locked-in stress;
- 931 – softening of thermoplastics;
- 932 – embrittlement of some materials due to loss of plasticiser;
- 933 – softening of some cross-linked materials particularly if the glass transition temperature of  
934 the material is exceeded;
- 935 – increased dielectric losses leading to thermal instability and failure.

936 High temperature gradients, for example during short-circuits, may cause mechanical failure.

#### 937 **4.7.4 Vibrations, transportation**

938 Mechanical stresses caused by vibration or shock during operation, storage or transportation  
939 may cause delamination, cracking or breaking-up of the insulating material (see 5.4.4.2).

#### 940 **4.7.5 Humidity**

941 The presence of water vapour can influence the **insulation** resistance and the discharge  
942 extinction voltage, aggravate the effect of surface contamination, produce corrosion and  
943 dimensional changes. For some materials, high humidity will significantly reduce the electric  
944 strength. Low humidity can be unfavourable in some circumstances, for example by  
945 increasing the retention of electrostatic charge and by decreasing the mechanical strength of  
946 some materials, such as polyamide.

#### 947 **4.7.6 Duration of voltage stress**

948 With regard to **creepage distances**, the time under voltage stress influences the number of  
949 occasions when drying out can result in surface scintillations with energy high enough to  
950 entail tracking. The number of such occasions is considered to be sufficiently large to cause  
951 tracking:

- 952 – in equipment intended for continuous use but not generating sufficient heat to keep the  
953 surface of the **insulation** dry;
- 954 – in equipment subjected to condensation for extended periods during which it is frequently  
955 switched ON and OFF;
- 956 – on the input side of a switching device, and between its line and load terminals, that is  
957 connected directly to the supply mains.

958 The **creepage distances** shown in Table F.5 have been determined for **insulation** intended  
959 to be under voltage stress during a long period of time (see 5.3.3.4).

#### 960 **4.8 Field distribution**

961 The electrical field influences the electric strength of insulation.

- 962 – The **homogenous field** distribution is the most favourable and theoretical case where the  
963 electrical field is completely homogeneous between two spheres (see 3.1.28). Typically, to  
964 achieve a **homogeneous field** conditions between two spheres, the radius of each sphere  
965 shall be greater than the distance between them. This case can never be reached in real  
966 design.

- 967 – The **inhomogeneous field** condition of a point-plane electrode configuration is the worst  
968 case with regard to voltage withstand capability and is referred to as case A. It is  
969 represented by a point electrode having a 30 µm radius and a plane of 1 m × 1 m.

970 In fact, the field distribution will normally be in between homogenous and inhomogenous field.

## 971 5 Design of insulation coordination

### 972 5.1 General

#### 973 5.1.1 Design of the insulation coordination

974 The design of the **insulation coordination** shall be realized by means of:

- 975 – **clearances** (5.2);
- 976 – **creepage distances** (5.3); and
- 977 – **solid insulation** (5.4)

978 and applies to each individual **insulation** under consideration.

#### 979 5.1.2 Frequency >30 kHz

980 Requirements to **insulation coordination** for equipment within **low-voltage systems** with  
981 rated frequencies above 30 kHz are given in IEC 60664-4.

#### 982 5.1.3 Reduced distances due to coating or potting

983 Requirements to **insulation coordination** for equipment within **low-voltage systems** using  
984 coating, potting or moulding for protection against **pollution**, allowing a reduction of  
985 **clearance** and **creepage distances** are given in IEC 60664-3.

### 986 5.2 Dimensioning of clearances

#### 987 5.2.1 General

988 **Clearance** dimensions shall be selected, taking into account the following influencing factors:

- 989 – **impulse withstand voltage** according to 5.2.2.2 for functional insulation, for **basic**  
990 **insulation, supplementary insulation** and **reinforced insulation**;
- 991 – **temporary withstand overvoltages** (see 5.2.2.4);
- 992 – **steady-state peak voltage and recurring peak voltages** (see 5.2.2.4);
- 993 – electric field conditions (see 5.2.3.2 and 5.2.3.3);
- 994 – altitude: (see 5.2.3.4);
- 995 – degrees of **pollution** in the **micro-environment** (see 4.5.2).

996 Larger **clearances** may be required due to mechanical influences such as vibration or applied  
997 forces.

#### 998 5.2.2 Dimensioning criteria for clearances

##### 999 5.2.2.1 General

1000 **Clearances** shall be dimensioned to withstand the largest of the following:

- 1001 - For circuits directly connected to the low-voltage mains, the **rated impulse withstand**  
1002 **voltage** determined on the basis of 5.2.2.2 and 5.2.2.3.
- 1003 - If a **steady-state peak voltage**, a **temporary overvoltage** or a **recurring peak voltage** is  
1004 present determined on the basis of 5.2.2.4.

1005 See Annex G for guidance how to determine clearance based on the requirement of 5.2.

##### 1006 5.2.2.2 Selection of rated impulse withstand voltage for equipment

1007 The **rated impulse withstand voltage** of the equipment shall be selected from Table F.1  
1008 corresponding to the **overvoltage category** specified and to the **rated voltage**  $U_n$  of the  
1009 equipment.

1010 NOTE 1 Equipment with a particular **rated impulse withstand voltage** and having more than one **rated voltage**  
1011 can be suitable for use in different **overvoltage categories**.

1012 NOTE 2 For consideration of the **switching overvoltage** aspect, see 4.2.2.4.

##### 1013 5.2.2.3 Dimensioning to withstand transient overvoltages

1014 **Clearances** shall be dimensioned to withstand the required **impulse withstand voltage**,  
1015 according to Table F.2. For circuits directly connected to the supply mains, the required

1016 **impulse withstand voltage** is the **rated impulse withstand voltage** established on the basis  
1017 of 5.2.2.2.

#### 1018 **5.2.2.4 Dimensioning to withstand steady-state peak voltages, temporary** 1019 **overvoltages or recurring peak voltages**

1020 **Clearances** shall be dimensioned according to Table F.8a to withstand the **steady-state peak**  
1021 **voltages**, the **temporary overvoltages** or the **recurring peak voltages**.

### 1022 **5.2.3 Other factors involving clearances**

#### 1023 **5.2.3.1 General**

1024 The shape and arrangement of the conductive parts (electrodes) influence the homogeneity of  
1025 the field (see 4.8) and consequently the **clearance** needed to withstand a given voltage (see  
1026 Table F.2, Table F.8a and Table A.1).

1027 It is recommended to design for inhomogeneous field condition according to 5.2.3.2 (case A)  
1028 during design. If designed for homogeneous field conditions according to 5.2.3.3 (case B),  
1029 5.2.3.3 applies (see also 6.2.2.1).

#### 1030 **5.2.3.2 Inhomogeneous field conditions (case A of Table F.2)**

1031 **Clearances** not less than those specified in Table F.2 for **inhomogeneous field** conditions  
1032 can be used irrespective of the shape and arrangement of the conductive parts and without  
1033 verification by a voltage withstand **test**.

1034 **Clearances** through openings in enclosures of insulating material shall not be less than those  
1035 specified for **inhomogeneous field** conditions since the configuration is not controlled, which  
1036 may have an adverse effect on the homogeneity of the electric field.

#### 1037 **5.2.3.3 Homogeneous field conditions (case B of Table F.2)**

1038 Values for **clearances** in Table F.2 for case B are only applicable for **homogeneous fields**.  
1039 They can only be used where the shape and arrangement of the conductive parts is designed  
1040 to achieve an electric field having an essentially constant voltage gradient.

1041 **Clearances** smaller than those for **inhomogeneous field** conditions require verification by a  
1042 voltage withstand **test** (see 6.2.2.1). For small values of **clearances**, the uniformity of the  
1043 electric field can deteriorate in the presence of **pollution**, making it necessary to increase the  
1044 **clearances** above the values of case B.

#### 1045 **5.2.3.4 Altitude correction**

1046 The **clearance** given in this document is valid up to 2 000 m.

1047 For altitude above 2 000 m, Table A.2 is a reference to determine the altitude correction  
1048 factors for clearance correction. See also 4.7.2 for the calculation procedure with respect to  
1049 altitude correction for clearances correction.

1050 Linear interpolation between two altitude values is not allowed.

### 1051 **5.2.4 Dimensioning of clearance of functional insulation**

1052 For a clearance of **functional insulation**, the required withstand voltage is the maximum  
1053 impulse voltage or **steady-state peak voltage** (with reference to Table F.8) or **recurring**  
1054 **peak voltage** (with reference to Table F.8) expected to occur across it, under rated conditions  
1055 of the equipment, and in particular the **rated voltage** and rated impulse voltage (refer to  
1056 Table F.2).

### 1057 **5.2.5 Dimensioning of clearances of basic insulation, supplementary insulation and** 1058 **reinforced insulation**

1059 **Clearances** of **basic insulation** and **supplementary insulation** shall each be dimensioned as  
1060 specified in Table F.2 corresponding to:

- 1061 – the **rated impulse withstand voltage**, according to 4.2.2 or 5.2.2.2; or
- 1062 – the internally generated transient over **withstand voltage** requirements according to  
1063 4.2.2.4;

1064 and as specified in Table F.8a corresponding to:

- 1065 – the **steady-state peak voltage** according to 4.2.6;
- 1066 – the **recurring peak voltage** according to 4.2.4; and
- 1067 – the **temporary overvoltage** according to 4.2.3.

1068 With respect to **impulse withstand voltages, clearances of reinforced insulation** shall be  
1069 dimensioned as specified in Table F.2 corresponding to the **rated impulse withstand voltage**  
1070 but one step higher in the preferred series of values in 4.2.2.1 than that specified for **basic**  
1071 **insulation**. If the **impulse withstand voltage** required for **basic insulation** according to  
1072 4.2.2.1, is other than a value taken from the preferred series, **reinforced insulation** shall be  
1073 dimensioned to withstand 160 % of the **impulse withstand voltage** required for **basic**  
1074 **insulation**.

1075 NOTE 1 In a coordinated system, **clearances** above the minimum required are unnecessary for a required  
1076 **impulse withstand voltage**. However, it can be necessary, for reasons other than **insulation coordination**, to  
1077 increase **clearances** (for example due to mechanical influences). In such instances, the **test voltage** is to remain  
1078 based on the **rated impulse withstand voltage** of the equipment, otherwise undue stress of associated **solid**  
1079 **insulation** can occur.

1080 With respect to **steady-state peak voltages, recurring peak voltages and temporary**  
1081 **overvoltages clearances of reinforced insulation** shall be dimensioned as specified in  
1082 Table F.8a to withstand 160 % of the **withstand voltage** required for **basic insulation**.

1083 For equipment provided with **double insulation** where **basic insulation** and **supplementary**  
1084 **insulation** cannot be tested separately, the **insulation** system is considered as **reinforced**  
1085 **insulation**.

1086 NOTE 2 When dimensioning **clearances** to accessible surfaces of insulating material, such surfaces are assumed  
1087 to be covered by metal foil. Further details can be specified by technical committees.

## 1088 5.2.6 Isolating devices

1089 Devices suitable for isolation are intended to disconnect and maintain for reasons of safety  
1090 adequate **clearance** from every source of electric energy. **Clearances** between lines and loads  
1091 terminals shall withstand the minimum impulse **withstand voltage** defined in 8.4.2 of  
1092 IEC 61140:2016.

## 1093 5.3 Dimensioning of creepage distances

### 1094 5.3.1 General

1095 To determine the required **creepage distances**, the following influencing factors must be  
1096 taken into account:

- 1097 - voltage (see 5.3.2.2);
- 1098 - **pollution degree** (see 5.3.2.3);
- 1099 - material group (see 5.3.2.4);
- 1100 - orientation and location of the **creepage distance** (see 5.3.3.2);
- 1101 - shape of insulating surface (see 5.3.3.3);
- 1102 - duration of the voltage stress (see 5.3.3.4);
- 1103 - components mounted on PWB (see 5.3.3.8).

1104 See Annex H for guidance how to determine creepage based on the requirement of 5.3.

1105 NOTE The values of Table F.5 are based upon existing empirical data and are suitable for the majority of  
1106 applications. However, for functional insulation, values of creepage distances other than those of Table F.5 can be  
1107 appropriate.

## 1108 5.3.2 Dimensioning criteria of creepage distances

### 1109 5.3.2.1 General

1110 **Creepage distances** shall be dimensioned to withstand the long term rms voltage stress  
1111 across the considered **insulation** and taking to account the **pollution degree** and the  
1112 material group over which the **creepage distance** is considered (see 5.3.2.2 to 5.3.2.4).  
1113 Other factors considering mechanical shape, material parameters and time under voltage  
1114 stress shall also be taken into account (see 5.3.3).

### 1115 5.3.2.2 Determination of the voltage

1116 The voltage to be used for the selection of the minimum **creepage distances** in Table F.5  
1117 shall be in accordance with the rationalized voltages of Table F.3 and Table F.4. They may  
1118 also be used for the selection of **rated insulation voltages**.

1119 For equipment having several **rated voltages** so that it may be used at different nominal  
1120 voltages of the low-voltage mains, the voltage selected shall be appropriate for the highest  
1121 **rated voltage** of the equipment.

1122 The highest **steady-state working voltage** which can occur in the system, equipment or  
1123 internal circuits shall be used. The voltage is determined for supply at **rated voltage** and  
1124 under the worst case operating conditions within the rating of the equipment.

1125 Fault conditions are not taken into account.

1126 The basis for the determination of a **creepage distance** is the long-term r.m.s. value of the  
1127 voltage existing across it. This voltage is the **steady-state working voltage** (see 4.2.5), the  
1128 **rated insulation voltage** (see 5.3.4) or the **rated voltage** (see 5.3.4).

1129 **Transient overvoltages** are neglected since they will normally not influence the tracking  
1130 phenomenon. However, **temporary overvoltages** should be considered if their duration and  
1131 frequency of occurrence can influence tracking (see 5.3.3.4).

### 1132 5.3.2.3 Determination of the pollution degree

1133 The influence of the **pollution degree**, considering the combination of **pollution** and humidity  
1134 in the **micro-environment** (see 4.5.2), shall be taken into account when dimensioning  
1135 **creepage distances** according to Table F.5

1136 NOTE In an equipment, different micro-environmental conditions can exist.

### 1137 5.3.2.4 Determination of the material group

1138 For the purposes of this document, materials are classified into four groups according to their  
1139 CTI values. These values are determined in accordance with IEC 60112 using solution A. The  
1140 groups are as follows:

- 1141 – material group I:  $600 \leq \text{CTI}$ ;
- 1142 – material group II:  $400 \leq \text{CTI} < 600$ ;
- 1143 – material group IIIa:  $175 \leq \text{CTI} < 400$ ;
- 1144 – material group IIIb:  $100 \leq \text{CTI} < 175$ .

### 1145 5.3.2.5 Relationship of creepage distance to clearance

1146 A **creepage distance** cannot be less than the associated clearance so that the shortest  
1147 **creepage distance** possible is equal to the required clearance. However, there is no physical  
1148 relationship, other than this dimensional limitation, between the minimum clearance in air and  
1149 the minimum acceptable **creepage distance**.

1150 Creepage distances less than the **clearances** required in case A of Table F.2 may only be  
1151 used under conditions of **pollution degrees** 1 and 2 when the **creepage distance** can  
1152 withstand the voltage required for the associated clearance (Table F.2). For testing, see 6.2.1.

## 1153 5.3.3 Other factors involving creepage distances

### 1154 5.3.3.1 General

1155 Technical committees shall take into account other factors influencing creepage distance as  
1156 example orientation, shape of insulating surface. In case of specificity can influence creepage  
1157 distances, those criterias shall be specified to inform the user of that case.

### 1158 5.3.3.2 Orientation of a creepage distances

1159 If necessary, the manufacturer shall indicate the intended orientation of the equipment or  
1160 component in order that **creepage distances** are not adversely affected by the accumulation  
1161 of pollution for which they were not designed.

### 1162 5.3.3.3 Shape of insulating surface

1163 Shaping of insulating surfaces is effective for dimensioning of **creepage distances** under  
1164 **pollution degree 3** only. Preferably, the surface of **solid insulation** should include  
1165 transverse ribs and grooves that break the continuity of the leakage path caused by  
1166 **pollution**. Likewise, ribs and grooves may be used to divert any water away from **insulation**  
1167 which is electrically stressed. Joints or grooves joining conductive parts should be avoided  
1168 since they can collect **pollution** or retain water.

### 1169 5.3.3.4 Duration of the voltage stress

1170 The duration of the voltage stress influences the number of occasions when drying out can  
1171 result in surface scintillations with energy high enough to entail tracking. The number of such  
1172 occasions is considered to be sufficiently large to cause tracking:

- 1173 – in equipment intended for continuous use but not generating sufficient heat to keep the  
1174 surface of the **insulation** dry;
- 1175 – in equipment subjected to condensation for extended periods during which it is frequently  
1176 switched ON and OFF;
- 1177 – on the input side of a switching device, and between its line and load terminals, that is  
1178 connected directly to the supply mains.

1179 The **creepage distances** shown in Table F.5 have been determined for **insulation** intended  
1180 to be under voltage stress during a long period of time.

### 1181 5.3.3.5 Creepage distances where more than one material is used or more than one 1182 pollution degree occurs

1183 A **creepage distance** may be split in several portions of different materials and/or have  
1184 different **pollution degrees** if one of the **creepage distances** is dimensioned to withstand the  
1185 total voltage or if the total distance is dimensioned according to the material having the lowest  
1186 CTI and the highest **pollution degree**.

### 1187 5.3.3.6 Creepage distances split by floating conductive part

1188 A **creepage distance** may be split into several parts, made with the same **insulation**  
1189 material, including or separated by floating conductors as long as the sum of the distances  
1190 across each individual part is equal or greater than the **creepage distance** required if the  
1191 floating part did not exist.

1192 The minimum distance X for each individual part of the **creepage distance** is given in Table 1  
1193 (see also Example 11).

### 1194 5.3.3.7 Reduction of creepage distances with the use of a rib (ribs)

1195 Required **creepage distances** equal to or larger than 8 mm under **pollution degree 3**, may  
1196 be reduced by the use of a rib. The values of these reduced **creepage distances** are those  
1197 values listed in Table F.5 in brackets (see Note 4 of Table F.5). The rib shall have a minimum  
1198 width (W) of 20 % and a minimum height (H) of 25 % of the required **creepage distance**  
1199 including the rib as measured in Figure 2.

1200 Where more than one rib is used, the required **creepage distance** shall be divided into  
1201 sections equal to the number of wanted ribs. For each section the requirements of the above  
1202 paragraph shall apply. The minimum distance between the multiple ribs shall be equal to the  
1203 minimum width of the rib applicable for each section, measured from the base of the rib.

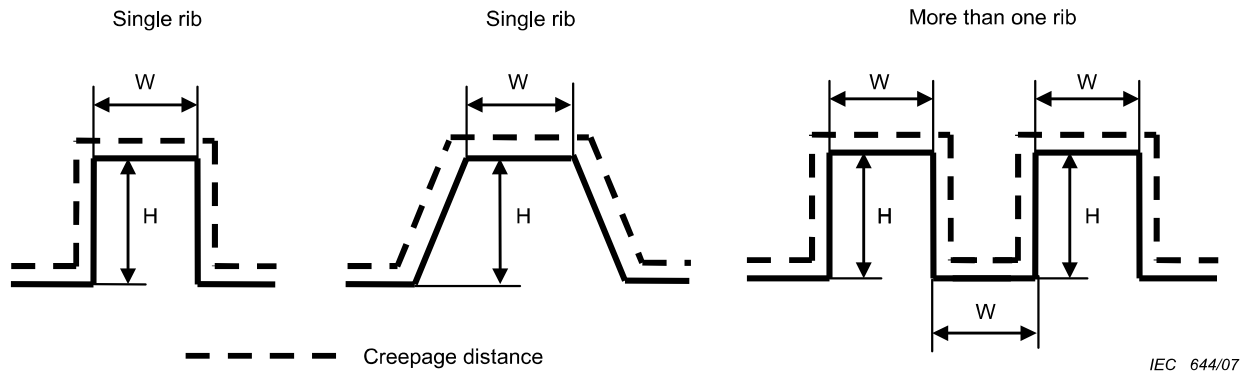

Figure 2 – Determination of the width (W) and height (H) of a rib

1204  
1205  
1206

### 1207 5.3.3.8 Creepage across component mounted on PWB

1208 For **creepage distances** on printed wiring material only used under pollution degree 1, a  
1209 reduced dimensioning is applicable and shall be selected from Table F.5. Attention is drawn  
1210 on the possible reduction or other path of **creepage distances** due to the components.

### 1211 5.3.4 Dimensioning of creepage distances of functional insulation

1212 Creepage distances of **functional insulation** shall be dimensioned as specified in Table F.5  
1213 corresponding to the **steady-state working voltage** across the **creepage distance**  
1214 considered.

1215 When the **steady-state working voltage** is used for dimensioning, it is allowed to interpolate  
1216 values for intermediate voltages. When interpolating, linear interpolation shall be used and  
1217 values shall be rounded to the same number of digits as the values picked up from the tables.

### 1218 5.3.5 Dimensioning of creepage distances of basic insulation, supplementary 1219 insulation and reinforced insulation

1220 **Creepage distances** of **basic insulation** and **supplementary insulation** shall be selected  
1221 from Table F.5 for:

- 1222 – the rationalized voltages given in columns 2 and 3 of Table F.3 and columns 2, 3 and 4 of  
1223 Table F.4b, corresponding to the nominal voltage of the supply low-voltage mains;
- 1224 – the **rated insulation voltage** according to 4.3.2;
- 1225 – the voltage specified in 4.3.3.

1226 Technical committees responsible for equipment in which **insulation** is under voltage stress  
1227 for only a short time may consider allowing reduced **creepage distances** (see 5.3.3.4).

1228 When Table F.5 is used, it is allowed to interpolate values for intermediate voltages. When  
1229 interpolating, linear interpolation shall be used and values shall be rounded to the same  
1230 number of digits as the values picked up from the tables.

1231 **Creepage distances** of **double insulation** are the sum of the values of the **basic insulation**  
1232 and **supplementary insulation** which make up the **double insulation** system.

1233 **Creepage distances** for **reinforced insulation** shall be twice the **creepage distance** for  
1234 **basic insulation**.

1235 NOTE 1 For **supplementary insulation**, the **pollution degree**, insulating material, mechanical stresses and  
1236 environmental conditions of use can be different from those for **basic insulation**.

1237 NOTE 2 For the purpose of the safety of persons and in order to reduce the risk of fire, the following restriction in  
1238 the use of the reduced values for creepage distances on printed wiring material under pollution degree 2 (column 3  
1239 in Table F.5) is required: The use of the reduced dimensioning values for creepage distances on printed wiring  
1240 material requires an additional protection against pollution. A solder resist of high quality is the minimum  
1241 requirement for this purpose.

1242 NOTE 3 When dimensioning **creepage distances** to accessible surfaces of insulating material, such surfaces are  
1243 assumed to be covered by metal foil. Further details can be specified by technical committees.

1244 Comparison of the minimum **clearances** and **creepage distances** specified in this document  
1245 is described in Annex F.

## 1246 5.4 Requirements for design of solid insulation

### 1247 5.4.1 General

1248 **Solid insulation of basic insulation, supplementary insulation and reinforced insulation**  
1249 shall be capable of durably withstanding electrical and mechanical stresses as well as thermal  
1250 and environmental influences which may occur during the intended life of the equipment.

1251 Technical committees shall consider these stresses when specifying conditions for **testing**.

### 1252 5.4.2 Voltage stress

1253 **Solid insulation** shall withstand the voltage stress considering:

- 1254 – **Transient overvoltages** according to 4.2.2;
- 1255 – **Temporary overvoltages** according to 4.2.3;
- 1256 – **Recurring peak voltage** according to 4.2.4;
- 1257 – **Steady-state working voltage** according to 4.2.6.

### 1258 5.4.3 Withstand of voltage stresses

#### 1259 5.4.3.1 Transient overvoltages

1260 **Basic insulation and supplementary insulation** shall have:

- 1261 – an **impulse withstand voltage** requirement corresponding to the nominal of the mains  
1262 voltage (see 4.2.2.3), and the relevant **overvoltage category** according to Table F.1; or
- 1263 – an **impulse withstand voltage** of an internal circuit of an equipment which has been  
1264 specified according to the **transient overvoltages** to be expected in the circuit (see  
1265 4.2.2.4).

1266 **Reinforced insulation** shall have an **impulse withstand voltage** corresponding to the **rated**  
1267 **impulse withstand voltage** but one step higher in the preferred series of values in 4.2.2.3  
1268 than that specified for **basic insulation**. If, according to 4.2.2.4, the **impulse withstand**  
1269 **voltage** required for **basic insulation** is other than a value taken from the preferred series,  
1270 **reinforced insulation** shall be dimensioned to withstand 160 % of the value required for  
1271 **basic insulation**.

1272 For verification by **testing**, see 6.3.4.

#### 1273 5.4.3.2 Temporary withstand overvoltages

1274 **Basic insulation and supplementary insulation of solid insulation** shall be designed to  
1275 withstand the following **temporary withstand overvoltages**:

- 1276 – short-term **temporary overvoltages** of  $U_n + 1\,200$  V with durations up to 5 s;
- 1277 – long-term **temporary overvoltages** of  $U_n + 250$  V with durations longer than 5 s;

1278 where  $U_n$  is the nominal line-to-neutral voltage of the neutral-earthed supply system.

1279 The performance validated can be declared by the manufacturer as a rated temporary  
1280 overvoltages value.

1281 **Reinforced insulation** shall withstand twice the **temporary withstand overvoltages**  
1282 specified for **basic insulation**.

1283 For verification by **testing**, see 6.3.5.

1284 NOTE 1 These values are from Clause 442 of IEC 60364-4-44:2007, where  $U_n$  is called  $U_o$ .

1285 NOTE 2 The values are r.m.s. values.

#### 1286 5.4.3.3 Recurring peak voltages

1287 The maximum **recurring peak voltages** occurring on the low-voltage mains can be assumed  
1288 provisionally to be  $F_4 \times \sqrt{2} U_n$ , i.e. 1,1 times the peak value at  $U_n$ . Where **recurring peak**  
1289 **voltages** are present, the partial discharge extinction voltage shall be at least:

1290 –  $F_1 \times F_4 \times \sqrt{2} U_n$ , i.e. 1,32  $\sqrt{2} U_n$  for each **basic insulation** and **supplementary**  
1291 **insulation**, and

1292 –  $F_1 \times F_3 \times F_4 \times \sqrt{2} U_n$ , i.e. 1,65  $\sqrt{2} U_n$  for **reinforced insulation**.

1293 NOTE  $\sqrt{2} U_n$  is in neutral-earthed systems the peak value of the line-to neutral fundamental (undistorted) voltage  
1294 at nominal voltage of mains. The application of the multiplying factors used in this subclause is described in  
1295 Annex D.

1296 For an explanation of factors  $F$ , see 6.3.6.1.

1297 In internal circuits, the highest **recurring peak voltages** have to be evaluated in place of  $F_4 \times$   
1298  $\sqrt{2} U_n$  and **solid insulation** shall meet the requirements correspondingly.

1299 For verification by **testing**, see 6.3.6.

#### 1300 **5.4.3.4 Steady-state working voltages**

1301 The **steady-state working voltage** is a long-term voltage stress applied on **solid insulation**.

1302 In those instances where **steady-state working voltages** are non-sinusoidal with periodically  
1303 recurring peaks, special consideration shall be given to possible occurrence of **partial**  
1304 **discharges**. Similarly, where **insulation** layers may exist and where voids in moulded  
1305 **insulation** may exist, consideration shall be given to possible occurrence of **partial**  
1306 **discharges** with resultant degradation of **solid insulation**.

1307 For verification by **testing**, see 6.3.6.

#### 1308 **5.4.4 Withstand on environmental stresses**

##### 1309 **5.4.4.1 Withstand of short-term heating stresses**

1310 **Solid insulation** shall not be impaired by short-term heating stresses which may occur in  
1311 normal and, where appropriate, abnormal use. Technical committees shall specify severity  
1312 levels.

1313 NOTE Standard severity levels are specified by the IEC 60068 Technical Committee.

##### 1314 **5.4.4.2 Withstand of mechanical stresses**

1315 **Solid insulation** shall not be impaired by mechanical vibration or shock which can be  
1316 expected in use. Technical committees shall specify severity levels.

1317 NOTE Standard severity levels are specified by the IEC 60068 Technical Committee.

##### 1318 **5.4.4.3 Withstand of long-term heating stresses**

1319 Thermal degradation of **solid insulation** shall not impair **insulation coordination** during the  
1320 intended life of the equipment. Technical committees shall specify whether a **test** is  
1321 necessary (see also IEC 60085 and IEC 60216 series).

##### 1322 **5.4.4.4 Withstand of the effects of humidity**

1323 **Insulation coordination** shall be maintained under the humidity conditions as specified for  
1324 the equipment (see also 6.3.3).

##### 1325 **5.4.4.5 Other factors impacting solid insulation**

1326 Equipment may be subjected to other stresses, for example as indicated in 4.6.2.4 which may  
1327 adversely affect **solid insulation**. Technical committees shall state such stresses and specify  
1328 **test** methods.

## 1329 **6 Tests and measurements**

### 1330 **6.1 General**

1331 The following **test** procedures apply to **type testing**, so that a possible deterioration of the  
1332 **test** specimen may be tolerated. It is assumed that further use of the **test** specimen is not  
1333 intended.

1334 **Test** procedures are specified for:

- 1335 – the verification of **clearances** (see 6.2);
- 1336 – the verification of **solid insulation** (see 6.3);
- 1337 – dielectric **tests** on complete equipment (see 6.4); and
- 1338 – other **tests** (see 6.5).

## 1339 **6.2 Test for verification of clearances**

### 1340 **6.2.1 General**

1341 The stresses for **clearances** caused by **transient overvoltages** are assessed by the impulse  
1342 voltage **test**, which may be substituted by an AC voltage **test** or a DC voltage **test**. See  
1343 6.2.2.1.3.

1344 When electrical equipment is subjected to electric **tests** for verifying **clearances**, the **test**  
1345 shall be in accordance with **withstand voltage** requirements specified in 5.2.2. The  
1346 appropriate **test** for the verification of **clearances** is the impulse voltage **test**, but as stated in  
1347 5.2.3.3, the **test** is only required for **clearances** smaller than case A values of Table F.2.

1348 If the withstand against **steady-state voltages**, **recurring peak voltages** or **temporary**  
1349 **overvoltages** according to 5.2.2 is decisive for the dimensioning of **clearances** and if those  
1350 **clearances** are smaller than the case A values of Table F.8a, an AC **test** voltage according to  
1351 6.2.2.1.3.2 **test** is required.

1352 When verifying **clearances** within equipment by an impulse voltage **test**, it is necessary to  
1353 ensure that the specified impulse voltage appears at the clearance under **test**.

1354 NOTE 1 The electric **testing** of **clearances** will also stress the associated **solid insulation**.

1355 NOTE 2 For some cases, these **tests** also have to be applied to **creepage distances**, see 5.3.2.5.

1356 NOTE 3 For **testing** complete equipment, see 6.4.

### 1357 **6.2.2 Test voltages**

#### 1358 **6.2.2.1 Impulse voltage dielectric test**

##### 1359 **6.2.2.1.1 General**

1360 The purpose of this **test** is to verify that **clearances** will withstand specified **transient**  
1361 **overvoltages**. The impulse withstand **test** is carried out with a voltage having a 1,2/50  $\mu$ s  
1362 waveform with the values specified in Table F.6. For the waveform, 7.1 of IEC 61180:2016  
1363 applies. It is intended to simulate overvoltages of atmospheric origin and covers overvoltages  
1364 due to switching of low-voltage equipment.

1365 Due to the scatter of the **test** results of any impulse voltage **test**, the **test** shall be conducted  
1366 for a minimum of three impulses of each polarity with an interval of at least 1 s between  
1367 pulses.

1368 NOTE 1 The output impedance of the impulse generator cannot be higher than 500  $\Omega$ . When carrying out **tests** on  
1369 equipment incorporating components across the **test** circuit, a much lower virtual impulse generator impedance can  
1370 be specified (see 9.2 in IEC 61180:2016). In such cases, possible resonance effects, which can increase the peak  
1371 value of the **test** voltage, can be taken into account when specifying **test** voltage values.

1372 Technical committees may specify alternative dielectric **tests** according to 6.2.2.1.3.

1373 NOTE 2 Values given in Table F.6 are derived from the calculation in 4.7.2. For accuracy of information, they are  
1374 given with a high level of precision. For practical application, technical committees can choose to round the values.

##### 1375 **6.2.2.1.2 Selection of impulse test voltage**

1376 If an electric **test** for **insulation coordination** of equipment with respect to **clearances** is  
1377 required, for **clearances** smaller than case A as specified in Table F.2, the equipment shall  
1378 be tested with the impulse **test** voltage corresponding to the **rated impulse withstand**  
1379 **voltage** specified in accordance with 5.2.2.3. The impulse **test** voltages of Table F.6 apply.

1380 For the **test** conditions, technical committees shall specify temperature and humidity values.

1381 Technical committees shall consider whether **sampling tests** or **routine tests** have to be  
1382 carried out in addition to **type tests**.

1383 **6.2.2.1.3 Alternatives to impulse voltage dielectric tests**

1384 **6.2.2.1.3.1 General**

1385 Technical committees may specify an AC or DC voltage **test** for particular equipment as an  
1386 alternative method.

1387 While **tests** with AC and DC voltages of the same peak value as the impulse **test** voltage  
1388 specified in Table F.6 verify the withstand capability of **clearances**, they more highly stress  
1389 **solid insulation** because the voltage is applied for longer duration. They can overload and  
1390 damage certain **solid insulations**. Technical committees should therefore consider this when  
1391 specifying **tests** with AC or DC voltages as an alternative to the impulse voltage **test** given in  
1392 6.3.5.

1393 While it is possible to substitute an impulse voltage **test** for **clearances** by an AC voltage **test**  
1394 or by a DC voltage **test**, it is in principle not possible to substitute an AC voltage **test** for  
1395 **solid insulation** by an impulse voltage **test**. The main reasons for this are the different  
1396 propagation of the impulse voltages compared to power frequency voltages, especially in  
1397 complex circuits, and the dependency of the withstand characteristics of **solid insulation** on  
1398 the shape and the duration of the voltage stress.

1399 **6.2.2.1.3.2 Dielectric test with AC voltage**

1400 The waveshape of the sinusoidal power frequency **test** voltage shall be substantially  
1401 sinusoidal. This requirement is fulfilled if the ratio between the peak value and the r.m.s.  
1402 value is  $\sqrt{2} \pm 5\%$ . The peak value shall be equal to the impulse **test** voltage of Table F.6 and  
1403 applied for three cycles of the AC **test** voltage.

1404 **6.2.2.1.3.3 Dielectric test with DC voltage**

1405 The DC **test** voltage shall be substantially free of ripple. This requirement is fulfilled if the  
1406 ratio between the peak values of the voltage and the average value is  $1,0 \pm 3\%$ . The average  
1407 value of the DC **test** voltage shall be equal to the impulse **test** voltage of Table F.6 and  
1408 applied three times for 10 ms in each polarity.

1409 **6.2.2.1.4 Altitude correction for testing at altitude lower than 2 000 m**

1410 According to 5.2.3.4, the clearance is valid for equipment used up to 2 000 m above sea level.  
1411 At 2 000 m, the normal barometric pressure is 80 kPa, while at sea level the value is  
1412 101,3 kPa. See also 4.7.2.

1413 Due to the air's barometric pressure dependency, clearances tested according to 6.2.2.1, is  
1414 tested using higher impulse test voltages at locations lower than 2 000 m. Table F.6 gives the  
1415 impulse test voltage value for verifying clearances at altitudes below 2 000 m.

1416 For the purpose of testing, the factors of temperature, humidity and climatic variations of air  
1417 pressure are not taken into account provided that normal laboratory conditions exist.

1418 Normal laboratory conditions are specified in IEC 60068-1:

- 1419 – Temperature: 15 °C to 35 °C;
- 1420 – Air pressure: 86 kPa to 106 kPa at sea level;
- 1421 – Relative humidity: 25 % to 75 %.

1422 The basis for the calculation of the sea level values and data for determining test values for  
1423 other test locations is as follows:

1424 The altitude correction factors given in Table A.2 are considered in relation to the curve of  
1425 Figure A.1 The relationship is as follows:

1426 
$$k_u = \left( \frac{1}{k_d} \right)^m$$

1427 where

1428  $d$  is the **clearance** under consideration in millimetres;

- 1429  $k_U$  is the altitude correction for withstand voltage correction;
- 1430  $k_d$  is the altitude correction for clearance correction (see Table F.9);
- 1431  $m$  is the gradient of the relevant straight line in curve 1 in Figure A.1 (logarithmic scales  
1432 on the two co-ordinate axes) and has the value.
- 1433  $m = 0,9163$  for  $0,001 < d \leq 0,01$  mm;
- 1434  $m = 0,3305$  for  $0,01 < d \leq 0,0625$  mm;
- 1435  $m = 0,6361$  for  $0,0625 < d \leq 1$  mm;
- 1436  $m = 0,8539$  for  $1 < d \leq 10$  mm;
- 1437  $m = 0,9243$  for  $10 < d \leq 100$  mm.

1438 Applying altitude correction for clearance correction results in curve 1 of Figure A.1, the  
1439 voltages will be changed with five different steps at only one shifting step for distance. The  
1440 mathematical formula for this operation is shown above. Table F.6 includes this calculation as  
1441 described.

1442 In other words, each value of  $k_d$  (altitude correction factor for clearance correction) will  
1443 produce five different values of  $k_U$  (altitude correction factor for withstand voltage correction)  
1444 based on the five different gradients ( $m$ ) of withstand voltage as a function of clearance ( $m$   
1445 having a different value for each of the five ranges of clearance, as laid out above).

## 1446 6.3 Tests for the verification of solid insulation

### 1447 6.3.1 General

1448 The ability of **solid insulation** to withstand the voltage stresses has to be verified by a  
1449 voltage **test** in any case. The stresses caused by **transient overvoltages** are assessed by  
1450 the impulse voltage **test**, which may be substituted by an AC voltage **test** or a DC voltage  
1451 **test**. The stresses caused by an AC **steady-state voltage** stress can only be assessed by an  
1452 AC voltage **test**. The DC voltage **test** with a **test** voltage equal to the peak value of the AC  
1453 voltage is not fully equivalent to the AC voltage **test** due to the different withstand  
1454 characteristics of **solid insulation** for these types of voltages. However, in case of a pure DC  
1455 voltage stress, the DC voltage **test** is appropriate.

### 1456 6.3.2 Selection of tests

1457 **Solid insulation** that may be subjected to mechanical stresses during operation, storage,  
1458 transportation or installation shall be **tested** with respect to vibration and mechanical shock  
1459 before the dielectric **testing**. Technical committees may specify **test** methods.

1460 The **tests** for **insulation coordination** are **type tests**. Technical committees shall specify  
1461 which **type tests** are required for the respective stresses occurring in the equipment.

1462 NOTE Standard **test** methods are specified in the relevant part of IEC 60068 by the Technical Committee.

1463 They have the following objectives:

- 1464 a) The impulse voltage withstand **test** is to verify the capability of the **solid insulation** to  
1465 withstand the **rated impulse withstand voltage** (see 5.4.3.1);
- 1466 b) The AC voltage **test** is to verify the capability of the **solid insulation** to withstand:
- 1467 – the short-term **temporary overvoltage** (see 5.4.3.2);
  - 1468 – the **steady-state working voltage** (see 5.4.3.4);
  - 1469 – the **recurring peak voltage** (see 5.4.3.3).

1470 If the peak value of the AC **test** voltage is equal to or higher than the **rated impulse**  
1471 **withstand voltage**, the impulse voltage **test** is covered by the AC voltage **test**.

1472 **Solid insulation** has a different withstand characteristic compared to **clearances**, if the  
1473 time of stress is being increased the withstand capability will be decreased significantly.  
1474 Therefore, the AC voltage **test**, which is specified for the verification of the withstand  
1475 capability of **solid insulation**, is not allowed to be replaced by an impulse voltage **test**.

- 1476 c) The **partial discharge test**, generally used as a **routine test**, is to verify that no **partial**  
1477 **discharges** are maintained in the **solid insulation**:

- 1478 – at the **steady-state working voltage** (see 5.4.3.4);
- 1479 – at the long-term **temporary overvoltage** (see 5.4.3.2);
- 1480 – at the **recurring peak voltage** (see 5.4.3.3).

1481 d) The high-frequency voltage **test** is to verify the absence of failure due to dielectric heating  
1482 according to 6.3.8

1483 **Partial discharge tests** for **solid insulation** shall be specified if the peak value of the  
1484 voltages listed under c) exceeds 700 V and if the average field strength is higher than  
1485 1 kV/mm. The average field strength is the peak voltage divided by the distance between two  
1486 parts of different potential.

1487 The above **tests** may also be suitable as sample or **routine tests**. It is, however, the  
1488 responsibility of the technical committees to specify which **tests** shall be performed as sample  
1489 and **routine tests** in order to ensure the quality of the **insulation** during production. The  
1490 **tests** and conditioning, as appropriate, shall be specified with **test** parameters adequate to  
1491 detect faults without causing damage to the **insulation** (see 6.5.2).

1492 When performing **tests** on complete equipment, the procedure of 6.4 applies.

### 1493 **6.3.3 Conditioning**

1494 If not otherwise specified, the **test** shall be performed with a new **test** specimen. Conditioning  
1495 of the specimen by temperature and humidity treatment is intended to:

- 1496 – represent the most onerous normal service conditions;
- 1497 – expose possible weaknesses which are not present in the new condition.

1498 Technical committees shall specify the appropriate conditioning method from the following  
1499 recommended methods:

- 1500 a) dry heat (IEC 60068-2-2), in order to achieve a stable condition which may not exist  
1501 immediately after manufacture;
- 1502 b) dry heat cycle (IEC 60068-2-14), in order to induce the creation of voids which could  
1503 develop in storage, transportation and normal use;
- 1504 c) thermal shock (IEC 60068-2-14), in order to induce delamination within the **insulation**  
1505 system which may develop in storage, transportation and normal use;
- 1506 d) damp heat (IEC 60068-2-78), in order to evaluate the effect of water absorption on the  
1507 electric properties of the **solid insulation**.

1508 For **impulse withstand voltage**, AC power frequency voltage and high frequency voltage  
1509 **tests**, the most significant conditioning methods are those in a) and d). For **partial discharge**  
1510 **testing**, the conditioning methods b) and c) are most relevant.

1511 If conditioning of **solid insulation** is required, it shall be performed prior to **type testing**. The  
1512 values of temperature, humidity and time shall be selected from Table F.7.

1513 It may be appropriate to subject components, for example electrical parts, sub-assemblies,  
1514 insulating parts and materials, to conditioning before electric testing. When components have  
1515 already been **type tested** according to this subclause, such conditioning is not required.

### 1516 **6.3.4 Impulse voltage test**

#### 1517 **6.3.4.1 Test method**

1518 The methods for impulse voltage testing of 6.2.2.1 apply also to **solid insulation**, except that  
1519 the altitude correction factors as listed in Table F.6 are not applicable. The **test** shall be  
1520 conducted for five impulses of each polarity with an interval of at least 1 s between impulses.  
1521 The waveshape of each impulse shall be recorded (see 6.3.4.2).

#### 1522 **6.3.4.2 Acceptance criteria**

1523 No **puncture** or partial breakdown of **solid insulation** shall occur during the **test**, but **partial**  
1524 **discharges** are allowed. Partial breakdown will be indicated by a step in the resulting  
1525 waveshape which will occur earlier in successive impulses.

1526 NOTE **Partial discharges** in voids can lead to partial notches of extremely short durations which can be repeated  
1527 in the course of an impulse.

### 1528 **6.3.5 AC power frequency voltage test**

#### 1529 **6.3.5.1 Test method**

1530 The waveshape of the sinusoidal power frequency **test** voltage shall be substantially  
1531 sinusoidal. This requirement is fulfilled if the ratio between the peak value and the r.m.s.  
1532 value is  $\sqrt{2} \pm 3\%$ . The peak value shall be equal to the highest of the voltages mentioned in  
1533 6.3.2 b).

1534 For **basic insulation** and **supplementary insulation**, the **test** voltage has the same value as  
1535 the voltages mentioned in 6.3.2 b). For **reinforced insulation**, the **test** voltage is twice the  
1536 value used for **basic insulation**.

1537 The AC **test** voltage shall be raised uniformly from 0 V to the value specified in 5.4.3.2 within  
1538 not more than 5 s and held at that value for at least 60 s.

1539 In those cases where the short term **temporary overvoltage** leads to the most stringent  
1540 requirements with respect to the amplitude of the **test** voltage, a reduction of the duration of  
1541 the **test** to a minimum value of 5 s can be considered by technical committees.

1542 NOTE 1 For particular types of **insulation**, longer periods of **testing** can be required to detect weakness within  
1543 the **solid insulation**.

1544 NOTE 2 In case of **testing** with respect to high, steady-state stresses including high **recurring peak voltage**,  
1545 technical committees can consider introducing a safety margin on the **test** voltage.

1546 In some cases, the AC **test** voltage needs to be substituted by a DC **test** voltage of a value  
1547 equal to the peak value of the AC voltage, however this **test** will be less stringent than the AC  
1548 voltage **test**. Technical committees shall consider this situation (see 6.3.7).

1549 **Test** equipment is specified in IEC 61180. It is recommended that the short-circuit output  
1550 current of the generator is not less than 200 mA.

1551 NOTE 3 For **test** voltages exceeding 3 kV, it is sufficient that the rated power of the **test** equipment is equal to or  
1552 greater than 600 VA.

1553 The tripping current of the generator shall be adjusted to a tripping current of 100 mA or for  
1554 **test** voltages above 6 kV to the highest possible value.

1555 NOTE 4 For **routine testing**, the tripping current can be adjusted to lower levels but not less than 3,5 mA.

#### 1556 **6.3.5.2 Acceptance criteria**

1557 No breakdown of **solid insulation** shall occur.

### 1558 **6.3.6 Partial discharge test**

#### 1559 **6.3.6.1 General**

1560 The waveshape of the sinusoidal power frequency **test** voltage shall be substantially  
1561 sinusoidal. This requirement is fulfilled if the ratio between the peak value and the r.m.s.  
1562 value is  $\sqrt{2} \pm 5\%$ . The peak value of  $U_t$  (see Figure 3) shall be equal to the highest of the  
1563 voltages mentioned in 6.3.2 c) taking into account the multiplying factors  $F_1$ ,  $F_3$  and  $F_4$  as far  
1564 as applicable.

1565 **Partial discharge test** methods are described in Annex C. When performing the **test**, the  
1566 following multiplying factors apply. These examples are given for the **recurring peak voltage**  
1567  $U_{rp}$ , the factors similarly apply to the **steady-state peak voltage** and to the long-term  
1568 **temporary overvoltage**.

1569  $F_1$  Basic safety factor for PD **testing** and dimensioning **basic insulation** and **supplementary**  
1570 **insulation**.

1571 The PD extinction voltage may be influenced by environmental conditions, such as  
1572 temperature. These influences are taken into account by a basic safety factor  $F_1$  of 1,2.  
1573 The PD extinction voltage for **basic insulation** or **supplementary insulation** is therefore  
1574 at least  $1,2 U_{rp}$ .

1575  $F_2$  PD hysteresis factor.

1576 Hysteresis occurs between the PD inception voltage  $U_i$  and the PD extinction voltage  $U_e$ .  
 1577 Practical experience shows that  $F_2$  is not greater than 1,25. For **basic insulation** and  
 1578 **supplementary insulation**, the initial value of the **test** voltage is therefore  $F_1 \times F_2 \times U_{rp}$ ,  
 1579 i.e.  $1,2 \times 1,25 U_{rp} = 1,5 U_{rp}$ .

1580 NOTE This takes into account that PD can be initiated by **transient overvoltages** exceeding  $U_i$  and can be  
 1581 maintained, for example, by values of the **recurring peak voltage** exceeding  $U_e$ . This situation can require the  
 1582 combination of impulse and AC voltages for the **test**, which is impractical. Therefore, an AC **test** is performed  
 1583 with an initially increased voltage.

1584  $F_3$  Additional safety factor for PD **testing** and dimensioning **reinforced insulation**.

1585 For **reinforced insulation** a more stringent risk assessment is required. Therefore, an  
 1586 additional safety factor  $F_3 = 1,25$  is required. The initial value of the **test** voltage is  $F_1 \times F_2$   
 1587  $\times F_3 \times U_{rp}$ , i.e.  $1,2 \times 1,25 \times 1,25 U_{rp} = 1,875 U_{rp}$ .

1588  $F_4$  Factor covering the deviation from the nominal voltage  $U_n$  of the low-voltage mains.

1589 For circuits connected to the low-voltage mains, this factor takes into account the  
 1590 maximum deviation of the mains voltage from its nominal value. Therefore, the crest  
 1591 voltage at nominal voltage  $U_n$  shall be multiplied by  $F_4 = 1,1$ .

### 1592 6.3.6.2 Verification

1593 The **test** is to verify that no **partial discharges** are maintained at the highest of the following  
 1594 values:

- 1595 – the peak value of the **working voltage** (see 5.4.3.4);
- 1596 – the peak value of the long-term **temporary overvoltage** (see 5.4.3.2);
- 1597 – the **recurring peak voltage** (see 5.4.3.3).

1598 NOTE For cases where, additionally, the actual values of PD inception and extinction voltage are of interest, the  
 1599 measuring procedure is described in D.1.

1600 When **testing**, the PD **test** is generally applied to components, small equipment and one part  
 1601 of the equipment.

1602 The minimum required discharge extinction voltage shall be higher, by factor  $F_1$ , than the  
 1603 highest of the voltages listed above.

1604 According to the kind of **test** specimen, technical committees shall specify:

- 1605 – the **test** circuit (see C.1);
- 1606 – the measuring equipment (see C.3 and D.2);
- 1607 – the measuring frequency (see C.3.1 and D.3.3);
- 1608 – the **test** procedure (see 6.3.6.3).

### 1609 6.3.6.3 Test procedure

1610 The value of the **test** voltage  $U_t$  is 1,2 times the required **partial discharge extinction**  
 1611 **voltage**  $U_e$ . According to the **partial discharge** hysteresis (see 6.3.6.1), an initial value of  
 1612 1,25 times the **test** voltage shall be applied.

1613 The voltage shall be raised uniformly from 0 V up to the initial **test** voltage  $F_2 \times U_t$ , i.e.  $F_1 \times F_2$   
 1614  $= 1,2 \times 1,25 = 1,5$  times the highest of the voltages listed under 6.3.6.2. It is then kept  
 1615 constant for a specified time  $t_1$  not exceeding 5 s. If no **partial discharges** have occurred, the  
 1616 **test** voltage is reduced to zero after  $t_1$ . If a **partial discharge** has occurred, the voltage is  
 1617 decreased to the **test** voltage  $U_t$ , which is kept constant for a specified time  $t_2$  until the **partial**  
 1618 **discharge** magnitude is measured.

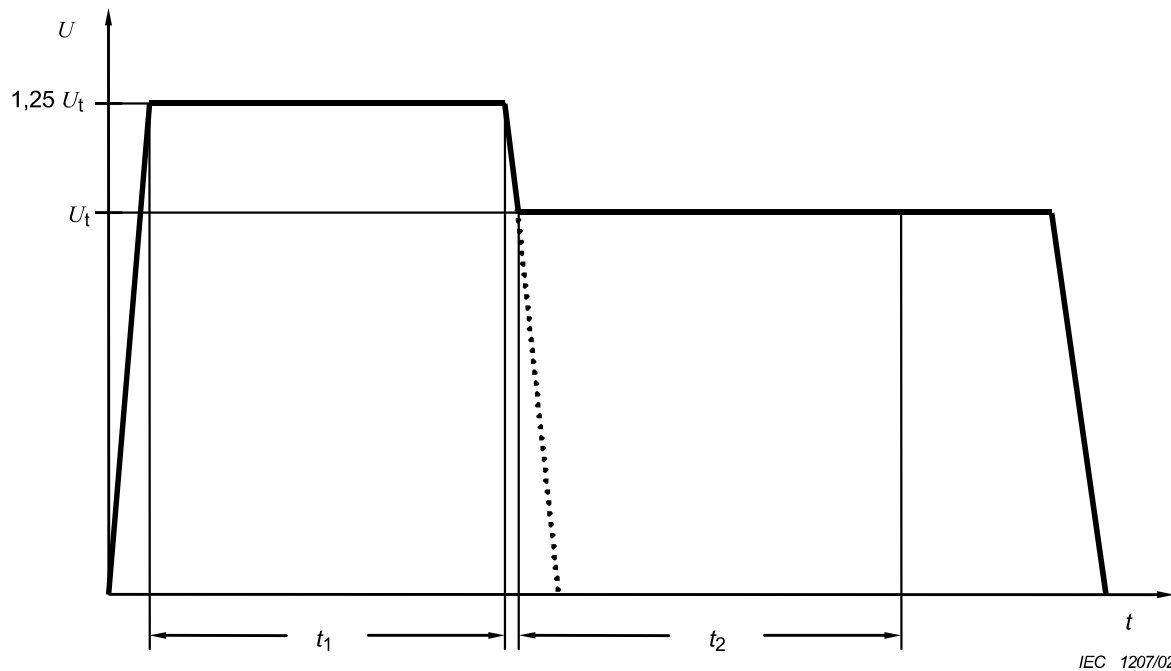

Figure 3 – Test voltages

1619

1620

#### 1621 6.3.6.4 Acceptance criteria

##### 1622 6.3.6.4.1 Specified discharge magnitude

1623 As the objective is to have no continuous **partial discharges** under normal service conditions,  
1624 the lowest practicable value shall be specified (see C.3).

1625 NOTE 1 Except for discharges caused by corona discharges in air (e.g. in non-moulded transformers), values in  
1626 excess of 10 pC are not suitable.

1627 NOTE 2 Values as small as 2 pC are possible with currently available apparatus.

1628 The noise level shall not be subtracted from the reading of the **partial discharge** meter.

##### 1629 6.3.6.4.2 Test result

1630 The **solid insulation** complies if:

- 1631 – no **insulation** breakdown has occurred; and
- 1632 – during the application of the **test** voltage, **partial discharges** have not occurred, or  
1633 after  $t_2$  the magnitude of the discharge is not higher than specified.

#### 1634 6.3.7 DC voltage test

1635 The DC voltage **test** with a **test** voltage equal to the peak value of the AC voltage is not fully  
1636 equivalent to the AC voltage **test** due to the different withstand characteristics of **solid**  
1637 **insulation** for these types of voltages. However, in case of a pure DC voltage stress, the DC  
1638 voltage **test** is well appropriate.

1639 The DC **test** voltage shall be substantially free of ripple. This requirement is fulfilled if the  
1640 ratio between the peak values of the voltage and the average value is  $1,0 \pm 3 \%$ . The average  
1641 value of the DC **test** voltage shall be equal to the peak value of the AC **test** voltage  
1642 mentioned in 6.3.2 b).

1643 For **basic insulation** and **supplementary insulation**, the **test** voltage has the same value as  
1644 the voltages mentioned in 6.3.2 b). For **reinforced insulation**, the **test** voltage is twice the  
1645 value used for **basic insulation**.

1646 The DC **test** voltage shall be raised uniformly from 0 V to the value specified in 5.4.3.2 within  
1647 not more than 5 s and held at that value for at least 60 s.

1648 NOTE 1 In certain cases, the charging current due to capacitances can be too high and a longer rise time can be  
1649 necessary.

1650 **Test** equipment is specified in IEC 61180. It is recommended that the short-circuit output  
1651 current of the generator is not less than 200 mA.

1652 NOTE 2 For **test** voltages exceeding 3 kV, it is sufficient that the rated power of the **test** equipment is equal or  
1653 greater than 600 VA.

1654 The tripping current of the generator shall be adjusted to a tripping current of 100 mA or for  
1655 **test** voltages above 6 kV to the highest possible value.

1656 NOTE 3 For **routine testing**, the tripping current can be adjusted to lower levels but not less than 10 mA.

### 1657 **6.3.8 High-frequency voltage test**

1658 For high-frequency voltages according to 6.3.2 d), additional or alternative AC voltage **tests**  
1659 according to 6.3.5 or **partial discharge tests** according to 6.3.6 may be necessary.

1660 NOTE Information about the withstand characteristics of **insulation** at high frequency and methods of **testing** is  
1661 given in IEC 60664-4.

## 1662 **6.4 Performing dielectric tests on complete equipment**

### 1663 **6.4.1 General**

1664 When performing the impulse voltage **test** on complete equipment, the attenuation or  
1665 amplification of the **test** voltage shall be taken into account. It needs to be assured that the  
1666 required value of the **test** voltage is applied across the terminals of the equipment under **test**.

1667 Surge protective devices (SPDs) shall be disconnected before dielectric **testing**.

1668 NOTE If capacitors with high capacitance are parallel to the parts between which the **test** voltage needs to be  
1669 applied, it can be difficult, or even impossible, to perform the AC voltage **test** because the charging current could  
1670 exceed the capacity of the high voltage tester (200 mA). In the latter case, those parallel capacitors can be  
1671 disconnected before **testing**. If this is also impossible, DC **testing** can be taken into consideration.

### 1672 **6.4.2 Parts to be tested**

1673 The **test** voltage shall be applied between parts of the equipment which are electrically  
1674 separate from each other.

1675 Examples of such parts include:

- 1676 – live parts;
- 1677 – separate circuits;
- 1678 – earthed circuits;
- 1679 – accessible surfaces.

1680 Non-conductive parts of accessible surfaces shall be covered with metal foil. If a complete  
1681 covering of large enclosures with metal foil is not practicable, a partial covering is sufficient if  
1682 applied to those parts which provide protection against electric shock.

### 1683 **6.4.3 Preparation of equipment circuits**

1684 For the **test**, each circuit of the equipment shall be prepared as follows:

- 1685 – external terminals of the circuit, if any, shall be connected together;
- 1686 – switchgear and controlgear within equipment shall be in the closed position or bypassed;
- 1687 – the terminals of voltage blocking components (such as rectifier diodes) shall be connected  
1688 together;
- 1689 – components such as RFI filters shall be included in the impulse **test** but it may be  
1690 necessary to disconnect them during AC **tests**.

1691 For the **test**, to include some specific components as follows:

- 1692 – voltage sensitive components within any circuit of the equipment, which do not bridge  
1693 **basic insulation** or **reinforced insulation**, may be bypassed by shorting the terminals;
- 1694 – pre-tested plug-in printed circuit boards and pre-tested modules with multipoint connectors  
1695 may be withdrawn, disconnected or replaced by dummy samples to ensure that the **test**  
1696 voltage is propagated inside the equipment to the extent necessary for the **insulation**  
1697 **tests**.

#### 1698 **6.4.4 Test voltage values**

1699 Circuits connected to the low-voltage mains are **tested** according to 6.2 and 6.3.

1700 The **test** voltage between two circuits of the equipment shall have the value corresponding to  
1701 the highest voltage that actually can occur between these circuits.

#### 1702 **6.4.5 Test criteria**

1703 There shall be no disruptive discharge (**sparkover**, **flashover** or **puncture**) during the **test**.  
1704 **Partial discharges** in **clearances** which do not result in breakdown are disregarded, unless  
1705 otherwise specified by the technical committees.

1706 NOTE It is recommended that an oscilloscope be used to observe the impulse voltage in order to detect disruptive  
1707 discharge.

### 1708 **6.5 Other tests**

#### 1709 **6.5.1 Test for purposes other than insulation coordination**

1710 Technical committees specifying electric **tests** for purposes other than verification of  
1711 **insulation coordination** shall not specify **test** voltages higher than those required for  
1712 **insulation coordination**.

#### 1713 **6.5.2 Sampling and routine tests**

1714 Sampling **tests** and **routine tests** are intended to ensure production quality. It is the  
1715 responsibility of the relevant technical committee, and in particular of the manufacturer, to  
1716 specify these **tests**. They shall be carried out with the waveforms and voltage levels such that  
1717 faults are detected without causing damage to the equipment (**solid insulation** or  
1718 components).

1719 Technical committees specifying **sampling** and **routine tests** shall in no case specify **test**  
1720 voltages higher than those required for **type testing**.

#### 1721 **6.5.3 Measurement accuracy of test parameters**

1722 All important **test** parameters shall be measured with high accuracy in order to provide well  
1723 defined and comparable **test** results. For the purpose of harmonization, the accuracy of  
1724 measurement of the measuring devices used for the following **test** parameters is given in this  
1725 document as follows:

- |      |                                 |           |
|------|---------------------------------|-----------|
| 1726 | a) <b>test</b> voltage (AC/DC): | ±3 %;     |
| 1727 | <b>test</b> voltage (impulse):  | ±5 %;     |
| 1728 | b) current:                     | ±1,5 %;   |
| 1729 | c) frequency:                   | ±0,2 %;   |
| 1730 | d) temperature:                 |           |
| 1731 | – below 100 °C                  | ±2 K;     |
| 1732 | – 100 °C up to 500 °C           | ±3 %;     |
| 1733 | e) relative humidity:           | ±3 % r.h. |

1734 NOTE The given accuracy refers to that of the humidity measuring device. It does not include the humidity  
1735 uniformity within the chamber and/or the influence of the **test** sample on the humidity uniformity. The humidity in  
1736 the chamber is measured only at one place before **testing** the sample.

- |      |  |  |
|------|--|--|
| 1737 | f) <b>partial discharge</b> magnitude: | ±10 % or ±1 pC (the greater values applies); |
| 1738 | g) time (impulse voltage)              | ±20 %;                                       |
| 1739 | time ( <b>test</b> duration)           | ±1 %.  |

### 1740 **6.6 Measurement of reducing the transient voltages attenuation**

1741 The proposed measurement (see 4.2.2.5) of the attenuation of transients is only possible by  
1742 use of a suitable impulse generator with very low output impedance.

1743 Such measurement may be performed by the use of the so called “Hybrid generator” or  
1744 “Combination wave generator” according to IEC 61000-4-5 with 2 Ω output impedance.

1745 **6.7 Measurement of clearances and creepage distances**

1746 The methods of measuring **clearances** and **creepage distances** are indicated in the following  
 1747 Examples 1 to 11. These cases do not differentiate between gaps and grooves or between  
 1748 types of **insulation**.

1749 The following assumptions are made:

- 1750 – where the distance across a groove is equal to or larger than the specified width  $X$  (see  
 1751 Table 1), the creepage distance is measured along the contours of the groove (see  
 1752 Example 2);
- 1753 – any recess is assumed to be bridged with an insulating link having a length equal to the  
 1754 specified width  $X$  and being placed in the most unfavourable position (see Example 3);
- 1755 – **clearances** and **creepage distances** measured between parts which can assume  
 1756 different positions in relation to each other, are measured when these parts are in their  
 1757 most unfavourable position.

1758 The dimension  $X$ , specified in the following examples, has a minimum value depending on the  
 1759 **pollution degree** as follows:

1760

**Table 1 – Dimensioning of grooves**

Pollution degree	Dimension $X$ minimum value
1	0,25 mm
2	1,0 mm
3	1,5 mm

1761

1762 If the associated **clearance** is less than 3 mm, the minimum dimension  $X$  may be reduced to  
 1763 one-third of the associated **clearance**.

1764

Example 1

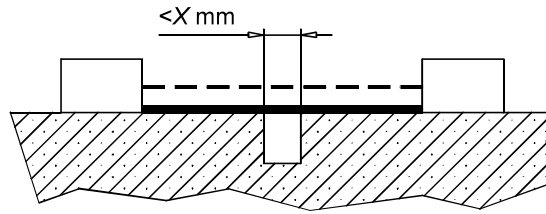

1765

1766

1767 Condition: Path under consideration includes a parallel- or converging-sided groove of any depth with a width less  
 1768 than  $X$  mm.

1769 Rule: **Clearance** and **creepage distance** are measured directly across the groove as shown.

1770

1771

Example 2

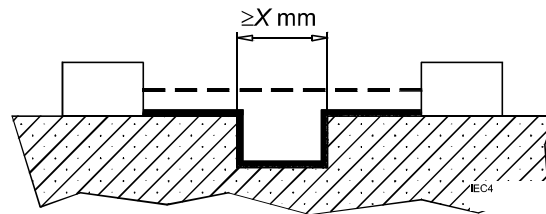

1772

1773

1774 Condition: Path under consideration includes a parallel-sided groove of any depth and equal to or more than  $X$  mm.

1775 Rule: **Clearance** is the "line of sight" distance. **Creepage** path follows the contour of the groove.

1776

1777

Example 3

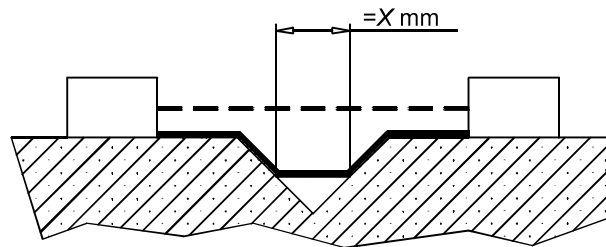

1778

1779

1780 Condition: Path under consideration includes a V-shaped groove with a width greater than  $X$  mm.

1781 Rule: **Clearance** is the "line of sight" distance. **Creepage** path follows the contour of the groove but "short-circuits"  
 1782 the bottom of the groove by  $X$  mm link.

1783

1784

Example 4

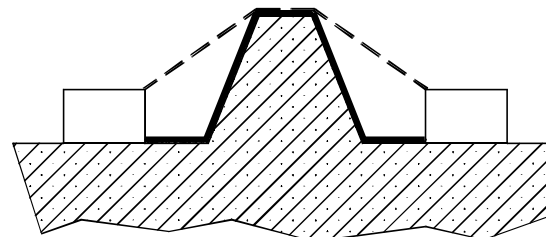

1785

1786

1787 Condition: Path under consideration includes a rib.

1788 Rule: **Clearance** is the shortest direct air path over the top of the rib. **Creepage** path follows the contour of the rib.

1789

1790

Example 5

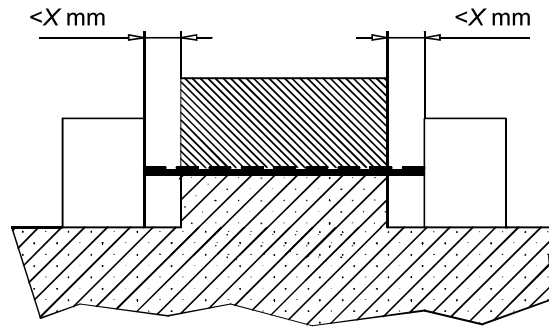

1791

1792

1793 Condition: Path under consideration includes an uncemented joint with grooves less than  $X$  mm wide on each side.

1794 Rule: **Clearance** and **creepage** path is the "line of sight" distance shown.

1795

1796

Example 6

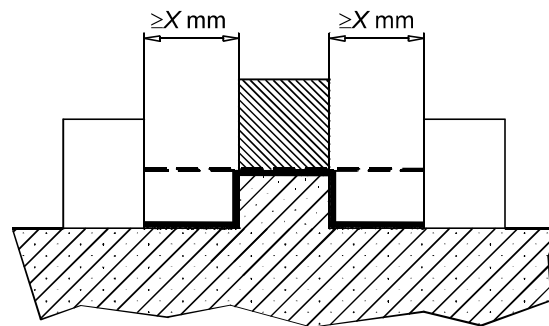

1797

1798

1799 Condition: Path under consideration includes an uncemented joint with grooves equal to or more than  $X$  mm wide on each side.

1800 Rule: **Clearance** is the "line of sight" distance. **Creepage** path follows the contour of the grooves.

1802

1803

Example 7

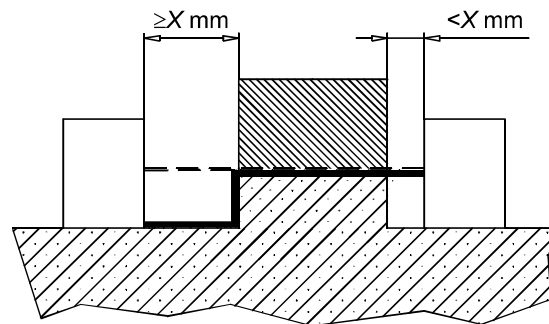

1804

1805 Condition: Path under consideration includes an uncemented joint with a groove on one side less than  $X$  mm wide and the groove on the other side equal to or more than  $X$  mm wide.

1806 Rule: **Clearance** and **creepage** paths area as shown.

1807

1808

1809

Example 8

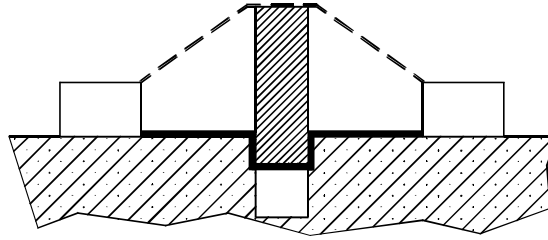

1810

1811 Condition: **Creepage distance** through uncemented joint is less than creepage distance over barrier but more than **clearance** over the top of the barrier.

1812 Rule: **Clearance** is the shortest direct air path over the top of the barrier.

1813

1814

1815

Example 9

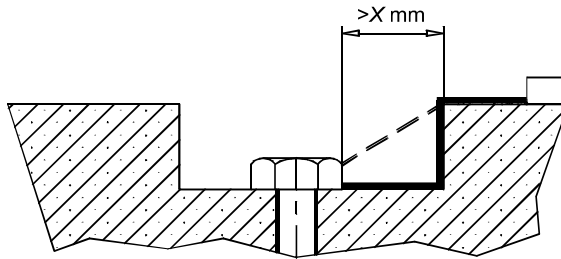

1816

1817 Gap between head of screw and wall of recess wide enough to be taken into account.

1818

1819

Example 10

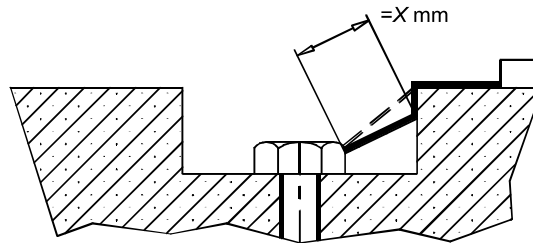

1820

1821

1822 Gap between head of screw and wall of recess too narrow to be taken into account.

1823 Measurement of **creepage distance** is from screw to wall when the distance is equal to X mm.

1824

1825

Example 11

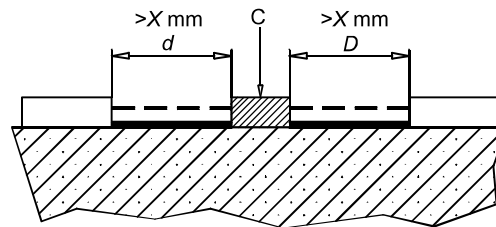

1826

1827

1828

1829

C conductive floating part

**Clearance** is the distance =  $d + D$

**Creepage distance** is also =  $d + D$

----- **Clearance**



**Creepage distance**

1830  
1831  
1832  
1833  
1834

## Annex A (informative)

### Basic data on withstand characteristics of clearances

1835 **Table A.1 – Withstand voltages in kilovolts for an altitude of 2 000 m above sea level**

Clearance	Case A Inhomogeneous field			Case B Homogeneous field	
	AC (50/60 Hz)		Impulse (1,2/50)	AC (50/60 Hz)	AC (50/60 Hz) and impulse (1,2/50)
mm	<i>U</i> r.m.s.	$\hat{U}$	$\hat{U}$	<i>U</i> r.m.s.	$\hat{U}$
0,001	0,028	0,040	0,040	0,028	0,040
0,002	0,053	0,075	0,075	0,053	0,075
0,003	0,078	0,110	0,110	0,078	0,110
0,004	0,102	0,145	0,145	0,102	0,145
0,005	0,124	0,175	0,175	0,124	0,175
0,00625	0,152	0,215	0,215	0,152	0,215
0,008	0,191	0,270	0,270	0,191	0,270
0,010	0,23	0,33+	0,33+	0,23	0,33+
0,012	0,25	0,35	0,35	0,25	0,35
0,015	0,26	0,37	0,37	0,26	0,37
0,020	0,28	0,40	0,40	0,28	0,40
0,025	0,31	0,44	0,44	0,31	0,44
0,030	0,33	0,47	0,47	0,33	0,47
0,040	0,37	0,52	0,52	0,37	0,52
0,050	0,40	0,56	0,56	0,40	0,56
0,0625	0,42	0,60+	0,60+	0,42	0,60+
0,080	0,46	0,65	0,70	0,50	0,70
0,10	0,50	0,70	0,81	0,57	0,81
0,12	0,52	0,74	0,91	0,64	0,91
0,15	0,57	0,80	1,04+	0,74	1,04
0,20	0,62	0,88	1,15	0,89	1,26
0,25	0,67	0,95	1,23	1,03	1,45
0,30	0,71	1,01	1,31	1,15	1,62
0,40	0,78	1,11	1,44	1,38	1,95
0,50	0,84	1,19	1,55	1,59	2,25
0,60	0,90	1,27	1,65	1,79	2,53
0,80	0,98	1,39	1,81	2,15	3,04
1,0	1,06	1,50+	1,95	2,47	3,50+
1,2	1,20	1,70	2,20	2,89	4,09
1,5	1,39	1,97	2,56	3,50	4,95
2,0	1,68	2,38	3,09	4,48	6,33
2,5	1,96	2,77	3,60	5,41	7,65
3,0	2,21	3,13	4,07	6,32	8,94
4,0	2,68	3,79	4,93	8,06	11,4
5,0	3,11	4,40	5,72	9,76	13,8
6,0	3,51	4,97	6,46	11,5	16,2
8,0	4,26	6,03	7,84	14,6	20,7
10,0	4,95	7,00+	9,10	17,7	25,0+
12,0	5,78	8,18	10,6	20,9	29,6
15,0	7,00	9,90	12,9	25,7	36,4
20,0	8,98	12,7	16,4	33,5	47,4
25,0	10,8	15,3	19,9	41,2	58,3
30,0	12,7	17,9	23,3	48,8	69,0
40,0	16,2	22,9	29,8	63,6	90,0
50,0	19,6	27,7	36,0	78,5	111,0
60,0	22,8	32,3	42,0	92,6	131,0
80,0	29,2	41,3	53,7	120,9	171,0

1836  
1837

1838

**Table A.1 (continued)**

Clearance	Case A Inhomogeneous field			Case B Homogeneous field	
	AC (50/60 Hz)		Impulse (1,2/50)	AC (50/60 Hz)	AC (50/60 Hz) and impulse (1,2/50)
mm	<i>U</i> r.m.s.	$\hat{U}$	$\hat{U}$	<i>U</i> r.m.s.	$\hat{U}$
100,0	35,4	50,0+	65,0	148,5	210,0+

NOTE The information for **clearances** from 0,001 mm to 0,008 mm, is issued from document "Electrical breakdown experiments in air for micrometer gaps under various pressures" from P. Hartherz, K. en Yahia, L. Müller, R. Pfendtner and W. Pfeiffer and issued during the 9<sup>th</sup> International Symposium on Gaseous Dielectrics, Ellicot City, Maryland, USA 2001, pp333-338.

More details can be found in the thesis of P. Hartherz "Anwendung der Teilentladungsmeßtechnik zur Fehleranalyse in festen Isolierungen unter periodischer Impulsspannungsbelastung". Dissertation TU Darmstadt; Shaker Verlag, 2002.

1839

1840 For simplification, the statistical measured values according to Table A.1 above are replaced  
 1841 by straight lines between the values marked "+" in a double logarithmic diagram taking into  
 1842 account the correction factors from 0 m to 2 000 m altitude. The intermediate values are taken  
 1843 from that diagram (see Figure A.1) so that they enclose the measured values with a small  
 1844 safety margin. The values of *U* r.m.s. are found by dividing the values of  $\hat{U}$  by  $\sqrt{2}$ .

1845

**Table A.2 – Altitude correction factors for clearance correction**

Altitude m	Normal barometric pressure kPa	Multiplication factor $k_d$ for clearances
2 000	80,0	1,00
3 000	70,0	1,14
4 000	62,0	1,29
5 000	54,0	1,48
6 000	47,0	1,70
7 000	41,0	1,95
8 000	35,5	2,25
9 000	30,5	2,62
10 000	26,5	3,02
15 000	12,0	6,67
20 000	5,5	14,5

1846

1847

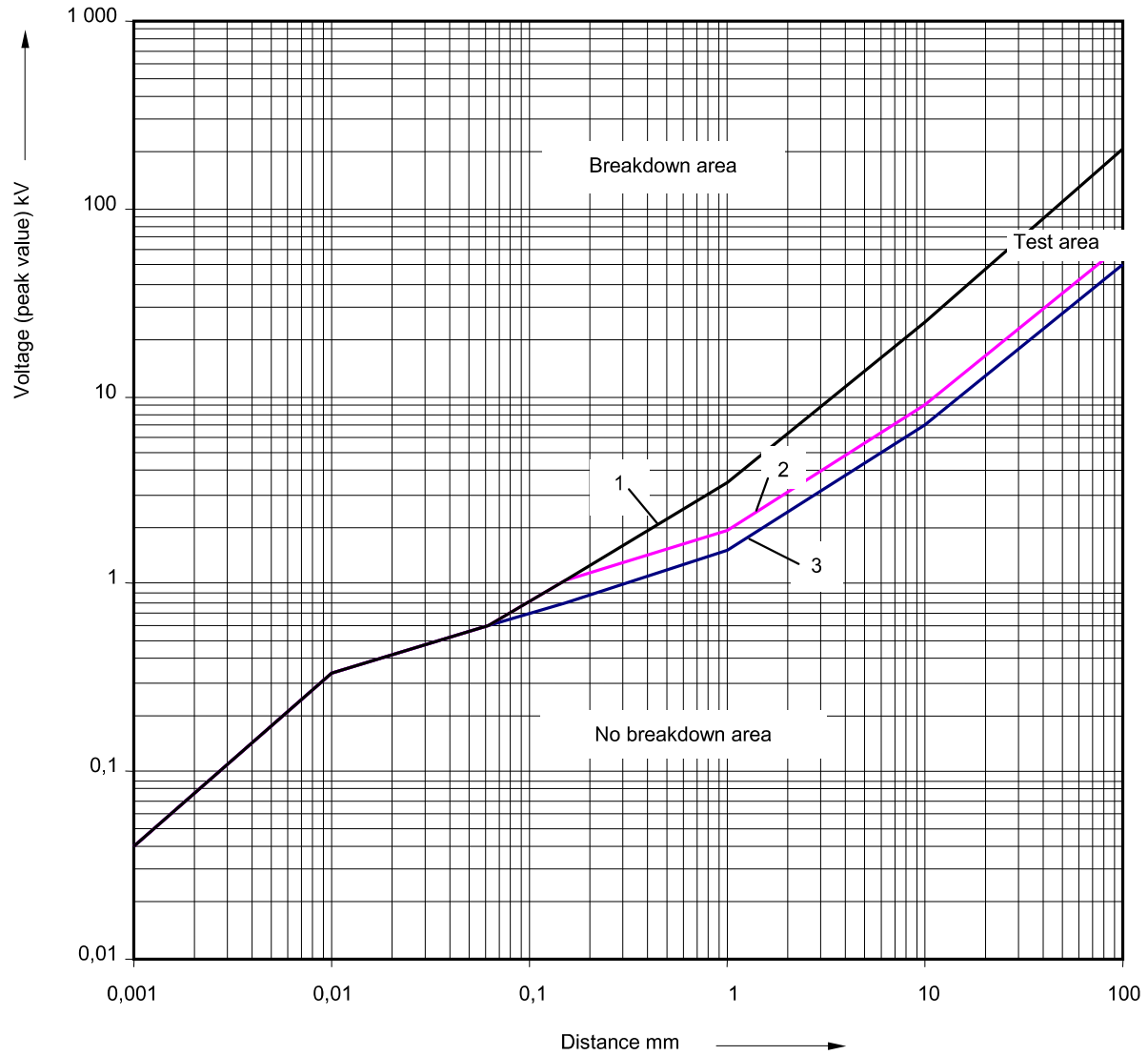

IEC 646/07

1848  
18491850 **Key**1851 1 case B;  $\hat{U}$  1,2/50 and  $\hat{U}$  50/60 Hz1852 2 case A;  $\hat{U}$  1,2/501853 3 case A;  $\hat{U}$  50/60 Hz1854 **Figure A.1 – Withstand voltage at 2 000 m above sea level**

1855

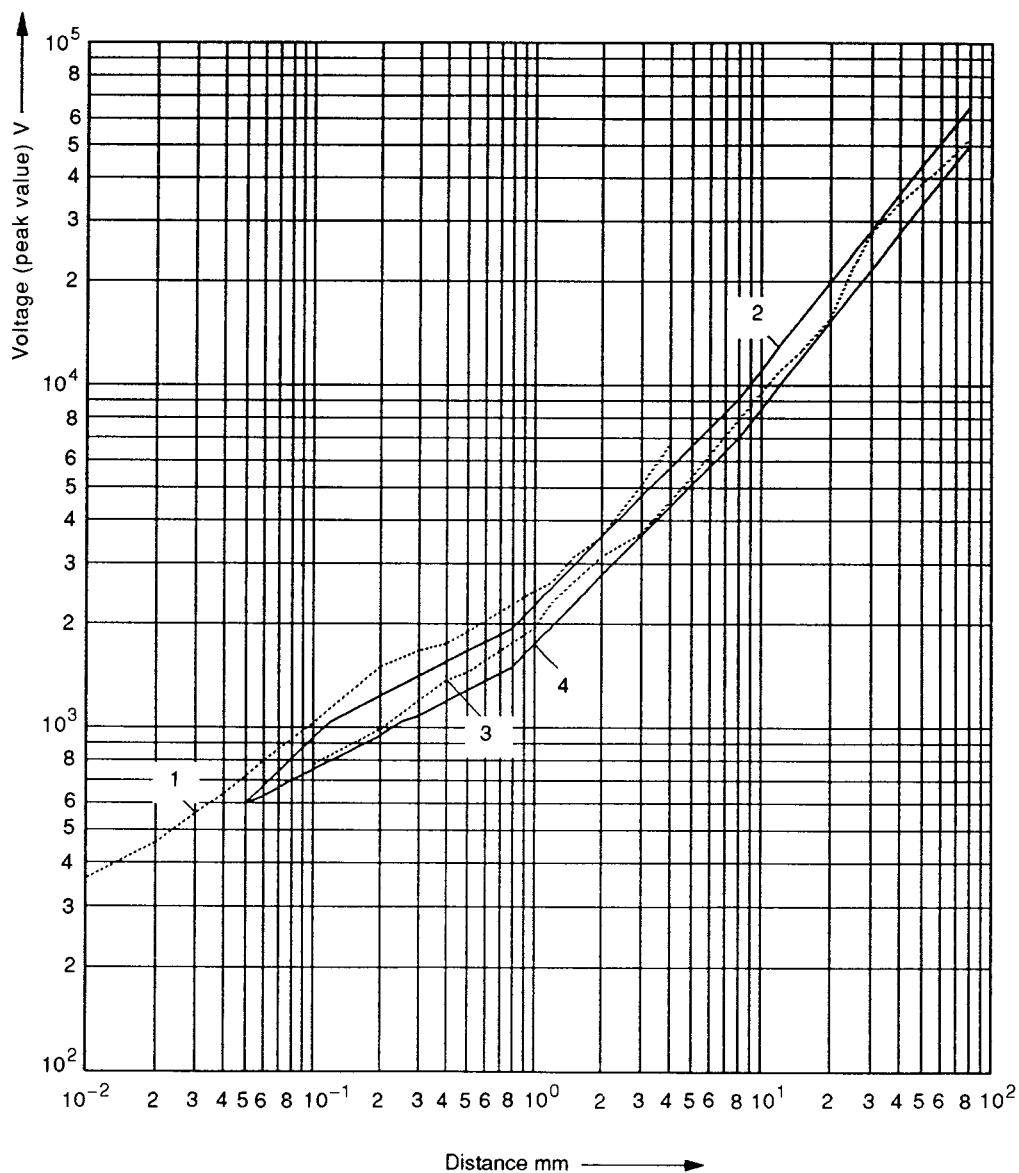

IEC 531/2000

1856

1857 **Key**1858 1  $\hat{U}$  1,2/50 according to ETZ-B, 1976 pp300-302 [1]1859 2 Low limits for  $\hat{U}$  1,2/501860 3  $\hat{U}$  50 Hz according to ETZ-A, 1969 pp251-255 [2]1861 4 Low limits for  $\hat{U}$  50 Hz

1862

**Figure A.2 – Experimental data measured at approximately sea level and their low limits for inhomogeneous field**

1863

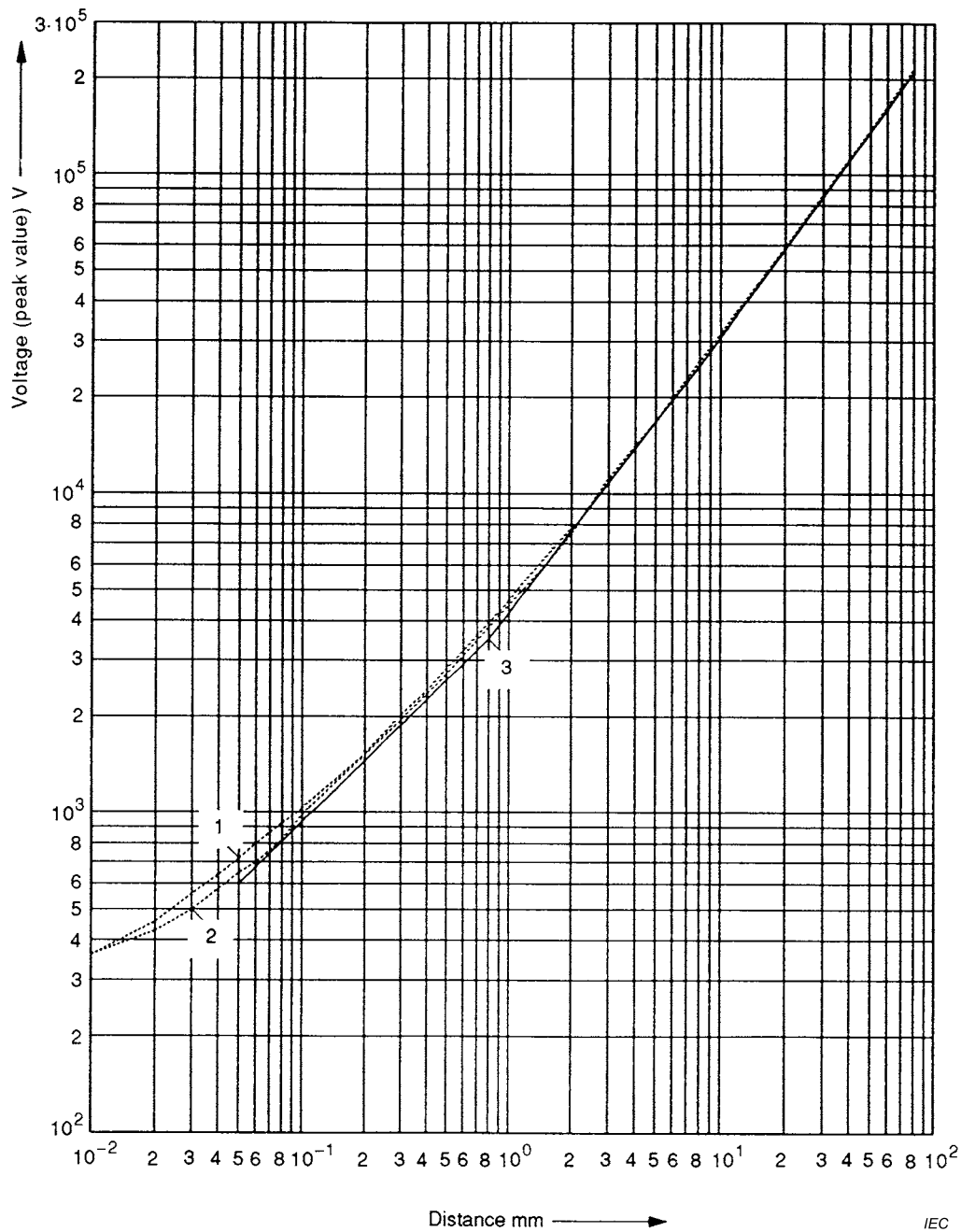

1864

Distance mm →

IEC 532/2000

1865 **Key**1866 1  $\dot{U}$  1,2/50 according to ETZ-B, 1976 pp300-302 [1]1867 2  $\dot{U}$  50 Hz according to Electra, 1974 pp61-82 [3]1868 3 Low limits for  $\dot{U}$  1,2/50 and  $\dot{U}$  50 Hz

1869

**Figure A.3 – Experimental data measured at approximately sea level and their low limits for homogeneous field**



1870

1871  
1872  
1873  
1874  
1875  
1876  
1877

## Annex B (informative)

### Nominal voltages of supply systems for different modes of overvoltage control

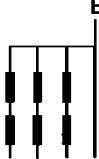
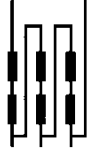
**Table B.1 – Inherent control or equivalent protective control**



Voltage line-to- neutral derived from nominal voltages AC or DC up to and including 1)	Nominal voltages presently used in the world				Rated impulse withstand voltage for equipment 1)  V			
	Three-phase four-wire systems  with earthed neutral  	Three-phase three-wire systems  unearthed  	Single- phase two-wire systems  AC or DC  	Single- phase three-wire systems  AC or DC  				
	V	V	V	V	V	I	II	III
50			12,5 24 25 30 42 48	30-60	330	500	800	1 500
100	66/115	66	60		500	800	1 500	2 500
150	120/208* 127/220	115, 120, 127	100**, 110, 120	100-200** 110-220 120-240	800	1 500	2 500	4 000
300	220/380, 230/400 240/415, 260/440 277/480	200 **, 220, 230, 240, 260, 277, 347 380, 400, 415 440, 480	220	220-440	1 500	2 500	4 000	6 000
600	347/600, 380/660 400/690, 417/720 480/830	500, 577, 600	480	480-960	2 500	4 000	6 000	8 000
1 000		660 690, 720 830, 1 000	1 000		4 000	6 000	8 000	12 000
1 500.			1 500	1 500	6 000	8 000	10 000	15 000

1) These columns are taken from Table F.1 in which the **rated impulse withstand voltage** values are specified.  
\* Practice in the United States of America and in Canada.  
\*\* Practice in Japan.

1878

1879  
1880  
1881

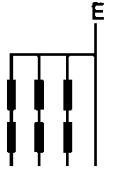
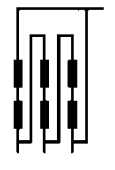
**Table B.2 – Cases where protective control is necessary and control is provided by surge protective device having a ratio of voltage protection level to rated voltage not smaller than that specified by IEC 61643 series**

Voltage line-to-neutral derived from nominal voltages AC or DC up to and including 1)	Nominal voltages presently used in the world				Rated impulse withstand voltage for equipment 1)  V			
	Three-phase four-wire systems  with earthed neutral  	Three-phase three-wire systems  earthed or unearthed  	Single-phase two-wire systems  AC or DC  	Single-phase three-wire systems  AC or DC.  				
	V	V	V	V	Overvoltage category			
					I	II	III	IV
50			12,5 24 25 30 42 48	30-60	330	500	800	1 500
100	66/115	66	60		500	800	1 500	2 500
150	120/208 * 127/220	115, 120, 127	100 ** 110, 120	100-200 ** 110-220 120-240	800	1 500	2 500	4 000
300	220/380, 230/400 240/415, 260/440 277/480	200 **, 220, 230, 240 260, 277	220	220-440	1 500	2 500	4 000	6 000
600	347/600, 380/660 400/690, 417/720 480/830	347, 380, 400 415, 440, 480 500, 577, 600	480	480-960	2 500	4 000	6 000	8 000
1 000		660 690, 720 830, 1 000	1 000		4 000	6 000	8 000	12 000

1) These columns are taken from Table F.1 in which the **rated impulse voltage** values are specified.  
\* Practice in the United States of America and in Canada.  
\*\* Practice in Japan.

1882

1883  
1884  
1885  
1886  
1887

## Annex C (normative)

### Partial discharge test methods

#### 1888 C.1 Test circuits

##### 1889 C.1.1 General

1890 **Test** circuits shall perform as described in IEC 60270. The following circuits given in this  
1891 annex meet those requirements and are given as examples.

1892 NOTE 1 In the majority of cases, **testing** equipment designed in accordance with the examples given in this  
1893 Annex will be sufficient. In special cases, for example in presence of extremely high ambient noise, it can be  
1894 necessary to refer to IEC 60270.

1895 NOTE 2 For an explanation of the basic operation, see Clause D.2.

##### 1896 C.1.2 Test circuit for earthed test specimen (Figure C.1)

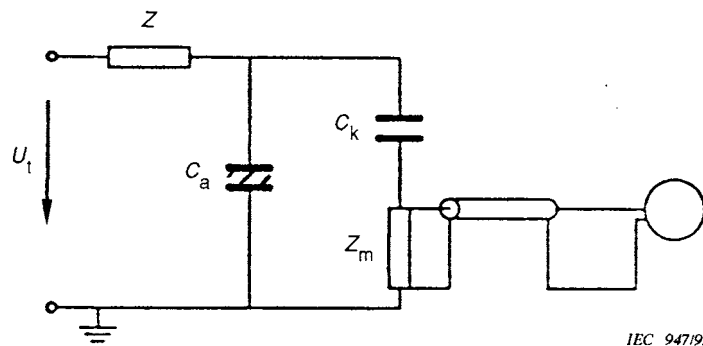

1897

##### 1898 Key

- 1899  $U_t$  test voltage  
1900  $Z$  filter  
1901  $C_a$  test specimen (usually it can be regarded as a capacitance)  
1902  $C_k$  coupling capacitor  
1903  $Z_m$  measuring impedance

1904

Figure C.1 – Earthed test specimen

##### 1905 C.1.3 Test circuit for unearthed test specimen (Figure C.2)

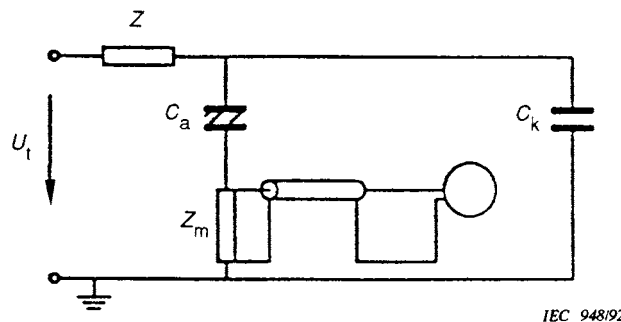

1906

1907

Figure C.2 – Unearthed test specimen

##### 1908 C.1.4 Selection criteria

1909 Basically, both circuits are equivalent. However, the stray capacitances of the **test** specimen  
1910 have a different influence upon sensitivity. The earth capacitance of the high-voltage terminal  
1911 of the **test** specimen tends to reduce the sensitivity of the circuit according to C.1.2 and tends  
1912 to increase the sensitivity of the circuit according to C.1.3 which therefore should be  
1913 preferred.

### 1914 **C.1.5 Measuring impedance**

1915 The measuring impedance shall provide a negligibly low-voltage drop at **test** frequency. The  
1916 impedance for the measuring frequency shall be selected in order to provide a reasonable  
1917 sensitivity according to Clause D.2.

1918 If voltage limiting components are used, they shall not be effective within the measuring  
1919 range.

### 1920 **C.1.6 Coupling capacitor $C_k$**

1921 This capacitor shall be of low inductance type with a resonant frequency in excess of  $3 f_2$  (see  
1922 Clause C.3). It shall be free of **partial discharges** up to the highest **test** voltage used.

### 1923 **C.1.7 Filter**

1924 The use of a filter is not mandatory. If used, its impedance shall be high for the measuring  
1925 frequency.

## 1926 **C.2 Test parameters**

### 1927 **C.2.1 General**

1928 Technical committees shall specify:

- 1929 – the frequency  $f_t$  of the **test** voltage (C.2.2);
- 1930 – the **specified discharge magnitude** (6.3.6.4.1);
- 1931 – the climatic conditions for the PD **test** (C.2.3).

1932 NOTE It can be necessary to have different specifications for the **type test** and the **routine test**.

### 1933 **C.2.2 Requirements for the test voltage**

1934 Normally AC voltages are used. The total harmonic distortion shall be less than 3 %.

1935 NOTE 1 Low distortion of the sine wave allows the use of standard voltmeters and the calculation of the peak  
1936 value from the r.m.s. reading. In the case of higher distortion, peak voltmeters can be used.

1937 **Tests** are normally made at power frequency. If other frequencies are present in the  
1938 equipment, technical committees shall consider the possible effect of frequency on discharge  
1939 magnitude.

1940 NOTE 2 PD **testing** with DC voltage is not recommended because of the difficulty of achieving an **environment**  
1941 which is completely free of electrical noise. In addition it can be noted that the voltage distribution is greatly  
1942 different for AC and DC.

### 1943 **C.2.3 Climatic conditions**

1944 It is recommended to perform the **test** at room temperature and average humidity (23 °C,  
1945 50 % r.h., see 4.3 of IEC 60068-1:2013).

## 1946 **C.3 Requirements for measuring instruments**

### 1947 **C.3.1 General**

1948 Both wideband and narrowband charge measuring instruments may be used (see C.3.3).  
1949 Radio interference voltmeters may only be used according to the precautions given in C.3.2.

1950 The lower limit of the measuring frequency is determined by the frequency  $f_t$  of the **test**  
1951 voltage and the frequency characteristic of the measuring impedance  $Z_m$  (see C.1.5). It  
1952 should not be lower than  $10 f_t$ .

1953 The upper limit of the measuring frequency is determined by the shape of the PD pulses and  
1954 the frequency response of the **test** circuit. It does not need to be higher than 2 MHz. For  
1955 narrowband PD meters the measuring frequency shall be selected with regard to narrowband  
1956 noise sources (see D.3.3).

1957 NOTE Narrowband PD meters are recommended.

### 1958 **C.3.2 Classification of PD meters**

1959 The current through the measuring impedance  $Z_m$  is integrated to provide a reading  
1960 proportional to  $q_m$  (see Figure D.1).

1961 The integration can be affected by the measuring impedance. In this case, it shall represent a  
1962 capacitance for all frequencies above the lower limit of the measuring frequency. The voltage  
1963 across the capacitance, which is proportional to  $q_m$ , is amplified by a pulse amplifier. Periodic  
1964 discharging shall also be provided.

1965 If the measuring impedance is resistive for all frequencies above the lower limit of the  
1966 measuring frequency, the integration shall be done within the pulse amplifier.

1967 Single pulses shall be measured and the pulse with the maximum amplitude shall be  
1968 evaluated. In order to limit errors due to pulse overlap, the pulse resolution time shall be less  
1969 than 100  $\mu\text{s}$ .

1970 Radio interference meters are narrowband peak voltage meters. They are used to measure  
1971 interference of radio signals. They incorporate a special filter circuit which creates  
1972 dependency of the reading on the **pulse repetition rate** according to the subjective effect of  
1973 noise to the human ear.

1974 For measuring **partial discharges**, radio interference meters may only be used if the filter  
1975 circuit is disconnected. Also, a suitable measuring impedance is required.

### 1976 **C.3.3 Bandwidth of the test circuit**

1977 Usually, the PD meter limits the bandwidth of the **test** circuit. PD meters are classified  
1978 according to their bandwidth as wideband or narrowband.

1979 a) The lower and the upper cut-off frequencies  $f_1$  and  $f_2$  are those where the frequency  
1980 response has dropped by 3 dB of the constant value in the case of a wideband meter and  
1981 by 6 dB from the peak value in the case of a narrowband meter.

1982 b) For narrowband meters, the measuring frequency  $f_0$  is identical with the resonance peak in  
1983 the frequency response.

1984 c) The bandwidth  $\Delta f$  is:

$$1985 \quad \Delta f = f_2 - f_1$$

1986 For wideband meters,  $\Delta f$  is in the same order of magnitude as  $f_2$ . For narrowband meters,  
1987  $\Delta f$  is much less than  $f_0$ .

## 1988 **C.4 Calibration**

### 1989 **C.4.1 Calibration of discharge magnitude before the noise level measurement**

1990 The calibration of the **test** circuit (Figure C.3 or Figure C.4) shall be carried out at the  
1991 **specified discharge magnitude** replacing the **test** specimen  $C_a$  by a capacitor  $C_x$  which  
1992 exhibits no **partial discharge**. The impedance of the capacitor  $C_x$  shall be similar to that of  
1993 the **test** specimen  $C_a$ .

1994 The transformers shall be adjusted according to the specified PD **test** voltage but not  
1995 energized and their primary windings shall be short-circuited. The **specified discharge**  
1996 **magnitude** shall be applied to the terminals of the capacitor by means of the calibration pulse  
1997 generator. The indication of the discharge magnitude on the discharge detector shall be  
1998 adjusted to correspond with the calibration signal.

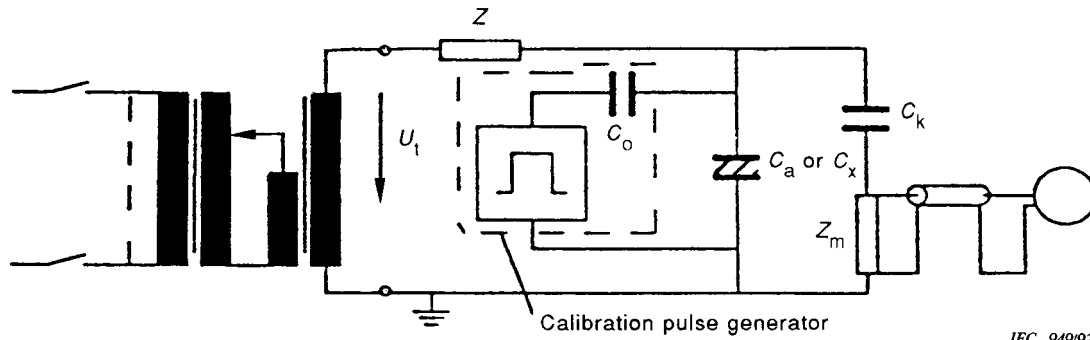

1999

2000 **Key**

2001	$U_t$	test voltage
2002	Z	filter
2003	$C_0$	capacitance of the calibration impulse generator
2004	$C_a$ or $C_x$	test specimen (usually it can be regarded as a capacitance)
2005	$C_k$	coupling capacitor
2006	$Z_m$	measuring impedance

2007

**Figure C.3 – Calibration for earthed test specimen**

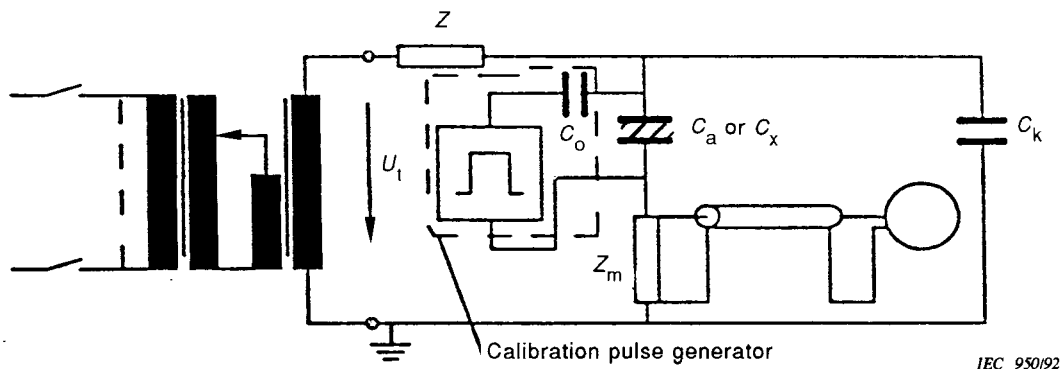

2008

2009

**Figure C.4 – Calibration for unearthed test specimen**

2010 **C.4.2 Verification of the noise level**

2011 With the arrangement used in C.4.1, the PD test voltage shall be raised up to the highest test  
 2012 voltage. The maximum noise level shall be less than 50 % of the specified discharge  
 2013 magnitude. Otherwise measures according to Clause D.3 are required.

2014 **C.4.3 Calibration for the PD test**

2015 With the test specimen in circuit, the procedure of C.4.1 shall be repeated.

2016 Changes in test circuit or test specimen require recalibration. In the case of many similar test  
 2017 specimens, occasional recalibration may be sufficient if:

- 2018 – the impedance of the coupling capacitor is less than 1/10 of that of the test specimen; or
- 2019 – the impedance of the test specimen does not deviate from the value during calibration by  
 2020 more than  $\pm 10\%$ .

2021 NOTE When specifying time intervals for recalibration, technical committees can bear in mind that, in case of  
 2022 insufficient sensitivity at the PD meter, potentially harmful discharges cannot be detected.

2023 **C.4.4 Calibration pulse generator**

2024 Basically, it consists of a small capacitance  $C_0$  which has been charged to  $U_0$ .

2025 The current pulses caused by the pulse generator should have a rise time of less than  
2026  $0,03 / f_2$ .  $C_o$  shall have no higher value than  $0,1 C_k$ . The tail time of the pulse should be  
2027 greater than  $100 \mu\text{s}$ .

2028 To verify the performance of the PD meter, it shall be calibrated in all measuring ranges. The  
2029 measuring impedance and the connecting cables shall be included in the procedure.

2030 The following characteristics shall be checked:

- 2031 – the precision and the stability of the calibration pulse generator;
- 2032 – the reading for pulses of different amplitudes at a **pulse repetition rate** of 100 Hz;
- 2033 – the pulse resolution time by using pulses of constant amplitude and increasing repetition  
2034 rate;
- 2035 – the lower and upper cut-off frequencies  $f_1$  and  $f_2$ .

2036 This procedure shall follow each time repairs are carried out on the PD meter but it shall in  
2037 any case take place at least once a year.

2038  
2039  
2040  
2041  
2042  
2043

## Annex D (informative)

### Additional information on partial discharge test methods

#### D.1 Measurement of PD inception and extinction voltage

2044 The **test** voltage is increased from a value below the **partial discharge inception voltage**  
2045 until **partial discharges** occur (PD inception voltage  $U_i$ ). After further increase of the **test**  
2046 voltage by 10 %, the voltage is decreased until PD is smaller than the **specified discharge**  
2047 **magnitude** (PD extinction voltage  $U_e$ ). Thereby the insulation **test** voltage specified for the  
2048 **test** specimen may not be exceeded.

2049 NOTE It can occur that the **partial discharge extinction voltage** is influenced by the time of the voltage stress  
2050 with values exceeding the **partial discharge inception voltage**. During successive measurements, both  $U_i$  and  $U_e$   
2051 can be influenced.

2052 This procedure is appropriate for investigation measurements.

#### D.2 Description of PD test circuits (Figure D.1)

2054 Each circuit consists of the following devices:

- 2055 – the **test** specimen  $C_a$  (in special cases it may also be an impedance  $Z_a$ );
- 2056 – the coupling capacitor  $C_k$ ;
- 2057 – the measuring circuit consisting of measuring impedance  $Z_m$ , the connecting cable and the  
2058 PD meter;
- 2059 – optionally a filter  $Z$  to reduce charge being bypassed by the **test** voltage source.

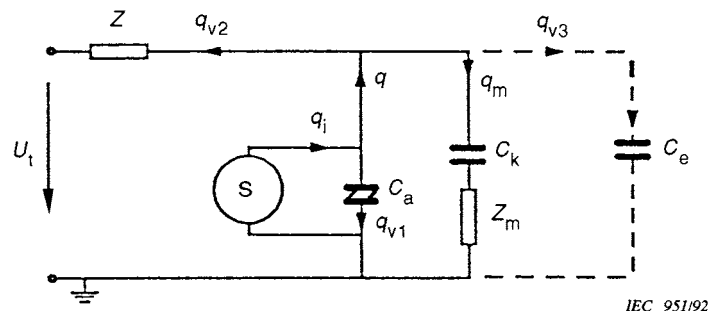

2060

#### Key

$U_t$	<b>test</b> voltage	$q_i$	internal charge (not measurable)
$Z$	filter	$q$	<b>apparent charge</b>
$S$	PD current source	$q_m$	measurable charge
$C_a$	capacitance of the <b>test</b> specimen	$q_{v1}$	charge loss across the <b>test</b> specimen
$C_k$	coupling capacitor	$q_{v2}$	charge loss across the <b>test</b> voltage source
$Z_m$	measuring impedance	$q_{v3}$	charge loss across the earth stray capacitance
$C_e$	earth stray capacitance		

2061

**Figure D.1 – Partial discharge test circuits**

2062 The direct measurement of the **apparent charge**  $q$  would require a short-circuit at the  
2063 terminals of the **test** specimen for the measuring frequency. This condition can be  
2064 approximated as follows:

- 2065 –  $C_k > (C_a + C_e)$ ;
- 2066 – high impedance  $Z$ ;
- 2067 – low measuring impedance  $Z_m$ .

2068 Otherwise significant charge losses  $q_{v2}$  and  $q_{v3}$  may occur. These charge losses are taken  
 2069 into account by the calibration but they will limit the sensitivity. The situation is aggravated if  
 2070 the **test** specimen has a high capacitance.

### 2071 **D.3 Precautions for reduction of noise**

#### 2072 **D.3.1 General**

2073 The results of PD measurements may be greatly influenced by noise. Such noise may be  
 2074 introduced by conductive coupling or by electromagnetic interference. In unscreened  
 2075 industrial **test** sites, single charge pulses as high as 100 pC may occur due to noise. Even  
 2076 under favourable conditions, not less than 20 pC may be expected.

2077 A noise level as low as 1 pC may be achieved, but this will require screening of the **test**  
 2078 circuit, careful earthing measures and filtering of the low-voltage mains input.

#### 2079 **D.3.2 Sources of noise**

2080 Basically, there are two different kinds of noise sources.

##### 2081 **D.3.2.1 Sources in the non-energized test circuit**

2082 These are caused for instance by switching in adjacent circuits. In case of conductive  
 2083 coupling they only occur if connection to the low-voltage mains supply is provided. In case of  
 2084 electromagnetic coupling they also occur if the mains supply is switched off (including the  
 2085 protective conductor).

##### 2086 **D.3.2.2 Sources in the energized test circuit**

2087 Usually, noise increases with the **test** voltage and is caused by **partial discharges** outside  
 2088 the **test** specimen. PD may occur in the **test** transformer, the high-voltage connecting leads,  
 2089 bushings and points of poor contact. Harmonics of the **test** voltage may also contribute to the  
 2090 noise level.

#### 2091 **D.3.3 Measures for reduction of noise**

2092 Noise caused by conductive coupling can be reduced by use of line filters in the central  
 2093 feeding of the **test** circuit. No earth loops should be present.

2094 Electromagnetic interference, for instance by radio signals, can be excluded in a simple  
 2095 manner by variation of the measuring frequency  $f_0$  for narrowband PD meters. For wideband  
 2096 PD meters, band-stop-filters may be required, wideband signals can only be suppressed by  
 2097 screening. The highest efficiency is provided by a fully enclosed screen with high electrical  
 2098 conductivity.

### 2099 **D.4 Application of multiplying factors for test voltages**

#### 2100 **D.4.1 General**

2101 The values of the multiplying factors defined in 6.3.6.1 and used in 5.4.3.3 and 6.3.6.1 are  
 2102 calculated as follows.

2103 NOTE These examples are given for the **recurring peak voltage**  $U_{rp}$ . The factors similarly apply to the **steady-**  
 2104 **state peak voltage** and to the long-term **temporary overvoltage**.

#### 2105 **D.4.2 Example 1**

2106 Circuit connected to the low-voltage mains.

##### 2107 **D.4.2.1 Maximum recurring peak voltage $U_{rp}$**

$$2108 \quad U_{rp} = \sqrt{2} U_n \times F_4 = 1,1 \sqrt{2} U_n$$

##### 2109 **D.4.2.2 PD extinction voltage $U_e$ (basic insulation)**

$$2110 \quad U_e = \sqrt{2} U_n \times F_4 \times F_1$$

2111 
$$U_e = \sqrt{2} U_n \times 1,1 \times 1,2 = 1,32 \sqrt{2} U_n$$

2112 **D.4.2.3 Initial value of the PD test voltage  $U_1$  (basic insulation)**

2113 
$$U_1 = \sqrt{2} U_n \times F_4 \times F_1 \times F_2$$

2114 
$$U_1 = \sqrt{2} U_n \times 1,32 \times 1,25 = 1,65 \sqrt{2} U_n$$

2115 **D.4.3 Example 2**

2116 Internal circuit with maximum **recurring peak voltage**  $U_{rp}$ .

2117 **D.4.3.1 PD extinction voltage  $U_e$  (basic insulation)**

2118 
$$U_e = U_{rp} \times F_1 = U_{rp} \times 1,2$$

2119 **D.4.3.2 Initial value of the PD test voltage (basic insulation)**

2120 
$$U_1 = U_{rp} \times F_1 \times F_2 = U_{rp} \times 1,5$$

2121  
2122  
2123  
2124  
2125  
2126

**Annex E**  
(informative)

**Comparison of creepage distances specified in Table F.5  
and clearances in Table A.1**

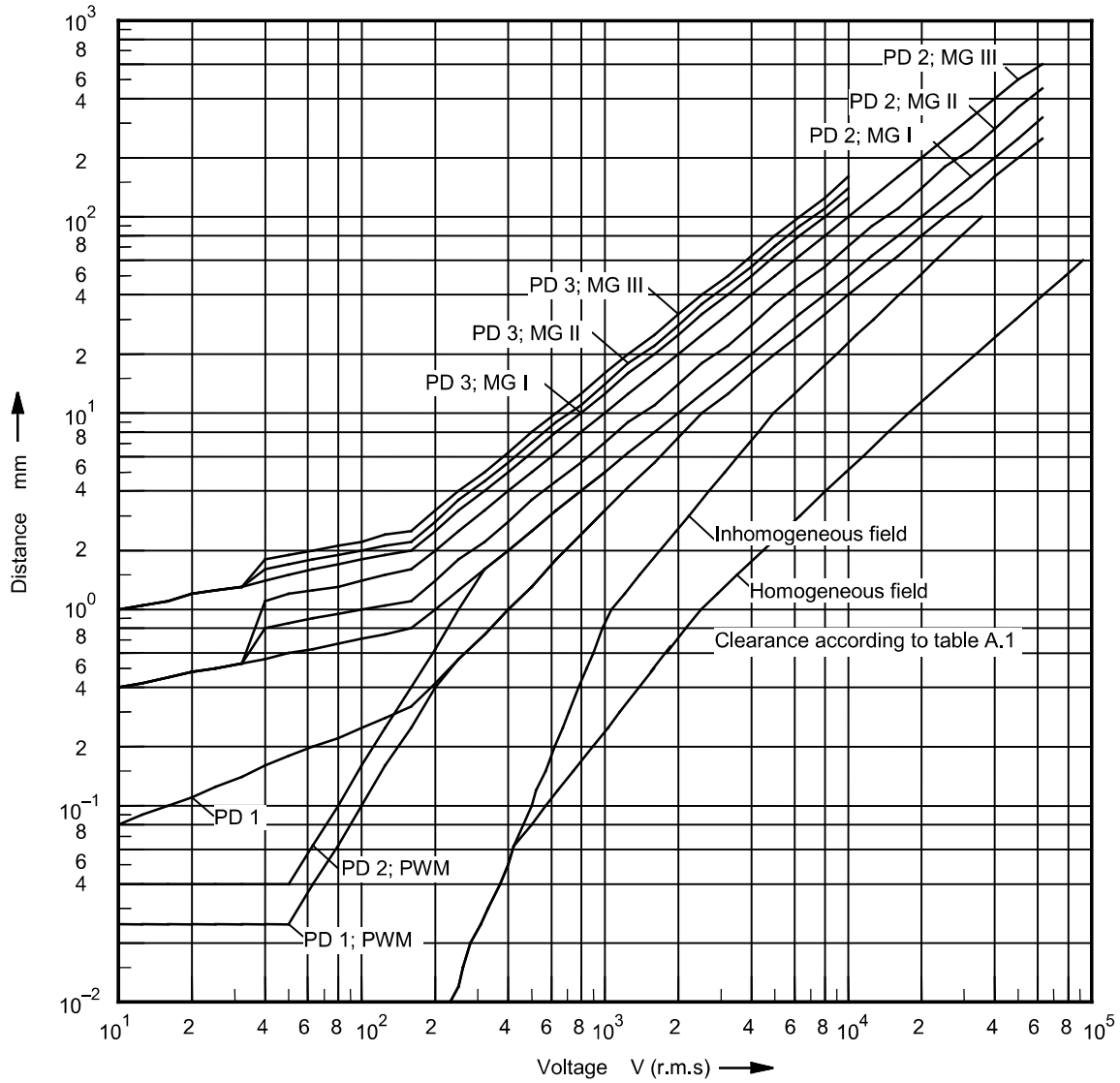

IEC 1208/02

2127  
2128 **Key**  
2129 PD pollution degree  
2130 MG material group  
2131 PWM printed wiring material

**Figure E.1 – Comparison between creepage distances specified in Table F.5  
and clearances in Table A.1**

2133

2134  
2135  
2136  
2137

## Annex F (normative)

### Tables

2138  
2139

**Table F.1 – Rated impulse withstand voltage for equipment energized directly from the low-voltage mains**

Nominal voltage of the supply system <sup>1)</sup> based on IEC 60038 <sup>3)</sup>		Voltage line to neutral derived from nominal voltages AC or DC up to and including  V	Rated impulse withstand voltage <sup>2)</sup>			
			Overvoltage category <sup>4)</sup>			
Three-phase V	Single phase V		I V	II V	III V	IV V
		50	330	500	800	1 500
		100	500	800	1 500	2 500
	120-240	150 <sup>5)</sup>	800	1 500	2 500	4 000
230/400 277/480		300	1 500	2 500	4 000	6 000
400/690		600	2 500	4 000	6 000	8 000
1 000		1 000	4 000	6 000	8 000	12 000
	1 500 <sup>6)</sup>	1 500 <sup>6)</sup>	6 000	8 000	10 000	15 000

1) See Annex B for application to existing different low-voltage mains and their nominal voltages.  
2) Equipment with this **rated impulse withstand voltage** can be used in installations in accordance with IEC 60364-4-44.  
3) The / mark indicates a four-wire three-phase distribution system. The lower value is the voltage line-to-neutral, while the higher value is the voltage line-to-line. Where only one value is indicated, it refers to three-wire, three-phase systems and specifies the value line-to-line.  
4) See 4.3 for an explanation of the **overvoltage categories**.  
5) Nominal voltages for single-phase systems in Japan are 100 V or 100-200 V. However, the value of the **rated impulse withstand voltage** for the voltages is determined from columns applicable to the voltage line to neutral of 150 V (see Annex B).  
6) For DC values only.

2140  
2141

2142

**Table F.2 – Clearances to withstand transient overvoltages**

Required impulse withstand voltage <sup>1) 5)</sup>	Minimum clearances in air up to 2 000 m above sea level					
	Case A Inhomogeneous field (see 3.1.29)			Case B Homogeneous field (see 3.1.28)		
	Pollution degree <sup>6)</sup>			Pollution degree <sup>6)</sup>		
kV	1 mm	2 mm	3 mm	1 mm	2 mm	3 mm
0,33 <sup>2)</sup>	0,01	0,2 <sup>3) 4)</sup>	0,8 <sup>4)</sup>	0,01	0,2 <sup>3) 4)</sup>	0,8 <sup>4)</sup>
0,40	0,02			0,02		
0,50 <sup>2)</sup>	0,04			0,04		
0,60	0,06			0,06		
0,80 <sup>2)</sup>	0,10			0,10		
1,0	0,15			0,15		
1,2	0,25	0,25	0,2	0,3	0,3	
1,5 <sup>2)</sup>	0,5	0,5				
2,0	1,0	1,0	1,0	0,45	0,45	
2,5 <sup>2)</sup>	1,5	1,5	1,5	0,60	0,60	
3,0	2,0	2,0	2,0	0,80	0,80	
4,0 <sup>2)</sup>	3,0	3,0	3,0	1,2	1,2	1,2
5,0	4,0	4,0	4,0	1,5	1,5	1,5
6,0 <sup>2)</sup>	5,5	5,5	5,5	2,0	2,0	2,0
8,0 <sup>2)</sup>	8,0	8,0	8,0	3,0	3,0	3,0
10	11	11	11	3,5	3,5	3,5
12 <sup>2)</sup>	14	14	14	4,5	4,5	4,5
15	18	18	18	5,5	5,5	5,5
20	25	25	25	8,0	8,0	8,0
25	33	33	33	10	10	10
30	40	40	40	12,5	12,5	12,5
40	60	60	60	17	17	17
50	75	75	75	22	22	22
60	90	90	90	27	27	27
80	130	130	130	35	35	35
100	170	170	170	45	45	45

1) This voltage is:  
– for functional insulation, for basic insulation directly exposed to or significantly influenced by **transient overvoltages** from the low-voltage mains (see 4.2.2, 5.2.2.3 and 5.4.3.1), the **rated impulse withstand voltage** of the equipment,  
– for other **basic insulation** (see 5.4.3), the highest impulse voltage that can occur in the circuit.  
For **reinforced insulation**, see 5.4.3.

2) Preferred values as specified in 4.2.2.

3) For printed wiring material, the values for **pollution degree** 1 apply except that the value shall not be less than 0,04 mm, as specified in Table F.5.

4) The minimum **clearances** given for **pollution degrees** 2 and 3 are based on the reduced withstand characteristics of the associated creepage distance under humidity conditions

5) For parts or circuits within equipment subject to **impulse withstand voltages** according to 5.4.3, interpolation of values is allowed. However, standardization is achieved by using the preferred series of impulse voltage values in 4.2.2.

6) The dimensions for **pollution degree** 4 are as specified for **pollution degree** 3, except that the minimum **clearance** is 1,6 mm.

2143

2144

2145

**Table F.3 – Single-phase three or two-wire AC. or DC systems**

Nominal voltage of the supply system *	Voltages rationalized for Table F.4	
	For insulation line-to-line <sup>1)</sup>	For insulation line-to-earth <sup>1)</sup>
	All systems V	Three-wire systems mid-point earthed V
V	V	V
12,5	12,5	
24 25	25	
30	32	
42 48 50 **	50	
60	63	
30-60	63	32
100 **	100	
110 120	125	
150 **	160	
200	200	
100-200	200	100
220	250	
110-220 120-240	250	125
300 **	320	
220-440	500	250
600 **	630	
480-960	1 000	500
1 000 **	1 000	
1 500 ***	1 500	

<sup>1)</sup> Line-to-earth **insulation** level for unearthed or impedance-earthed systems equals that for line-to-line because the operating voltage to earth of any line can, in practice, approach full line-to-line voltage. This is because the actual voltage to earth is determined by the **insulation** resistance and capacitive reactance of each line to earth; thus, low (but acceptable) **insulation** resistance of one line can in effect earth it and raise the other two to full line-to-line voltage to earth.

\* For relationship to **rated voltage** see 5.3.2.2

\*\* These values correspond to the values given in Table F.1.

\*\*\* For DC values only.

2146

2147

2148

**Table F.4 – Three-phase four or three-wire AC systems**

Nominal voltage of the supply system *	Voltages rationalized for Table F.5		
	For insulation line-to-line	For insulation line-to-earth	
	All systems	Three-phase four-wire systems neutral-earthed <sup>2)</sup>	Three-phase three-wire systems unearthed <sup>1)</sup> or corner-earthed
V	V	V	V
60	63	32	63
110 120 127	125	80	125
150 **	160	–	160
200	200		200
208	200	125	200
220 230 240	250	160	250
300 **	320	–	320
380 400 415	400	250	400
440	500	250	500
480 500	500	320	500
575	630	400	630
600 **	630	–	630
660 690	630	400	630
720 830	800	500	800
960	1 000	630	1 000
1 000 **	1 000	–	1 000

1) Line-to-earth **insulation** level for unearthed or impedance-earthed systems equals that for line-to-line because the operating voltage to earth of any line can, in practice, approach full line-to-line voltage. This is because the actual voltage to earth is determined by the **insulation** resistance and capacitive reactance of each line to earth; thus, low (but acceptable) **insulation** resistance of one line can in effect earth it and raise the other two to full line-to-line voltage to earth.

2) For equipment for use on both three-phase four-wire and three-phase three-wire supplies, earthed and unearthed, use the values for three-wire systems only.

\* For relationship to **rated voltage** see 5.3.2.2.

\*\* These values correspond to the values given in Table F.1.

2149

2150

2151

**Table F.5 – Creepage distances to avoid failure due to tracking**

Voltage r.m.s. <sup>1)</sup>	Minimum creepage distances								
	Printed wiring material		Pollution degree						
	1	2	1	2			3		
	All material groups	All material groups, except IIIb	All material groups	Material group I	Material group II	Material group III	Material group I	Material group II	Material group III <sup>2)</sup>
V	mm	mm	mm	mm	mm	mm	mm	mm	mm
10	0,025	0,040	0,080	0,400	0,400	0,400	1,000	1,000	1,000
12,5	0,025	0,040	0,090	0,420	0,420	0,420	1,050	1,050	1,050
16	0,025	0,040	0,100	0,450	0,450	0,450	1,100	1,100	1,100
20	0,025	0,040	0,110	0,480	0,480	0,480	1,200	1,200	1,200
25	0,025	0,040	0,125	0,500	0,500	0,500	1,250	1,250	1,250
32	0,025	0,040	0,14	0,53	0,53	0,53	1,30	1,30	1,30
40	0,025	0,040	0,16	0,56	0,80	1,10	1,40	1,60	1,80
50	0,025	0,040	0,18	0,60	0,85	1,20	1,50	1,70	1,90
63	0,040	0,063	0,20	0,63	0,90	1,25	1,60	1,80	2,00
80	0,063	0,100	0,22	0,67	0,95	1,30	1,70	1,90	2,10
100	0,100	0,160	0,25	0,71	1,00	1,40	1,80	2,00	2,20
125	0,160	0,250	0,28	0,75	1,05	1,50	1,90	2,10	2,40
160	0,250	0,400	0,32	0,80	1,10	1,60	2,00	2,20	2,50
200	0,400	0,630	0,42	1,00	1,40	2,00	2,50	2,80	3,20
250	0,560	1,000	0,56	1,25	1,80	2,50	3,20	3,60	4,00
320	0,75	1,60	0,75	1,60	2,20	3,20	4,00	4,50	5,00
400	1,0	2,0	1,0	2,0	2,8	4,0	5,0	5,6	6,3
500	1,3	2,5	1,3	2,5	3,6	5,0	6,3	7,1	8,0 (7,9) <sup>4)</sup>
630	1,8	3,2	1,8	3,2	4,5	6,3	8,0 (7,9) <sup>4)</sup>	9,0 (8,4) <sup>4)</sup>	10,0 (9,0) <sup>4)</sup>
800	2,4	4,0	2,4	4,0	5,6	8,0	10,0 (9,0) <sup>4)</sup>	11,0 (9,6) <sup>4)</sup>	12,5 (10,2) <sup>4)</sup>
1 000	3,2	5,0	3,2	5,0	7,1	10,0	12,5 (10,2) <sup>4)</sup>	14,0 (11,2) <sup>4)</sup>	16,0 (12,8) <sup>4)</sup>
1 250			4,2	6,3	9,0	12,5	16,0 (12,8) <sup>4)</sup>	18,0 (14,4) <sup>4)</sup>	20,0 (16,0) <sup>4)</sup>
1 600			5,6	8,0	11,0	16,0	20,0 (16,0) <sup>4)</sup>	22,0 (17,6) <sup>4)</sup>	25,0 (20,0) <sup>4)</sup>
2 000			7,5	10,0	14,0	20,0	25,0 (20,0) <sup>4)</sup>	28,0 (22,4) <sup>4)</sup>	32,0 (25,6) <sup>4)</sup>
2 500			10,0	12,5	18,0	25,0	32,0 (25,6) <sup>4)</sup>	36,0 (28,8) <sup>4)</sup>	40,0 (32,0) <sup>4)</sup>
3 200			12,5	16,0	22,0	32,0	40,0 (32,0) <sup>4)</sup>	45,0 (36,0) <sup>4)</sup>	50,0 (40,0) <sup>4)</sup>

2152

2153

2154

Table F.5 (continued)

Voltage r.m.s. <sup>1)</sup>	Minimum creepage distances								
	Printed wiring material		Pollution degree						
	1	2	1	2			3		
	All material groups	All material groups, except IIIb	All material groups	Material group I	Material group II	Material group III	Material group I	Material group II	Material group III <sup>2)</sup>
V	mm	mm	mm	mm	mm	mm	mm	mm	mm
4 000			16,0	20,0	28,0	40,0	50,0 (40,0) <sup>4)</sup>	56,0 (44,8) <sup>4)</sup>	63,0 (50,4) <sup>4)</sup>
5 000			20,0	25,0	36,0	50,0	63,0 (50,4) <sup>4)</sup>	71,0 (56,8) <sup>4)</sup>	80,0 (64,0) <sup>4)</sup>
6 300			25,0	32,0	45,0	63,0	80,0 (64,0) <sup>4)</sup>	90,0 (72,0) <sup>4)</sup>	100,0 (80,0) <sup>4)</sup>
8 000			32,0	40,0	56,0	80,0	100,0 (80,0) <sup>4)</sup>	110,0 (88,0) <sup>4)</sup>	125,0 (100,0) <sup>4)</sup>
10 000			40,0	50,0	71,0	100,0	125,0 (100,0) <sup>4)</sup>	140,0 (112,0) <sup>4)</sup>	160,0 (128,0) <sup>4)</sup>
12 500			50,0 <sup>3)</sup>	63,0 <sup>3)</sup>	90,0 <sup>3)</sup>	125,0 <sup>3)</sup>			
16 000			63,0 <sup>3)</sup>	80,0 <sup>3)</sup>	110,0 <sup>3)</sup>	160,0 <sup>3)</sup>			
20 000			80,0 <sup>3)</sup>	100,0 <sup>3)</sup>	140,0 <sup>3)</sup>	200,0 <sup>3)</sup>			
25 000			100,0 <sup>3)</sup>	125,0 <sup>3)</sup>	180,0 <sup>3)</sup>	250,0 <sup>3)</sup>			
32 000			125,0 <sup>3)</sup>	160,0 <sup>3)</sup>	220,0 <sup>3)</sup>	320,0 <sup>3)</sup>			
40 000			160,0 <sup>3)</sup>	200,0 <sup>3)</sup>	280,0 <sup>3)</sup>	400,0 <sup>3)</sup>			
50 000			200,0 <sup>3)</sup>	250,0 <sup>3)</sup>	360,0 <sup>3)</sup>	500,0 <sup>3)</sup>			
63 000			250,0 <sup>3)</sup>	320,0 <sup>3)</sup>	450,0 <sup>3)</sup>	600,0 <sup>3)</sup>			

1) This voltage is  
– for functional insulation, for basic insulation and supplementary insulation of the circuit energized directly from the supply mains (see 4.3.1), the voltage rationalized through Table F.3 or Table F.4, based on the rated voltage of the equipment, or the rated insulation voltage,  
– for **basic** insulation and **supplementary insulation** of systems, equipment and internal circuits not energized directly from the mains (see 4.3.2), the highest r.m.s. voltage which can occur in the system, equipment or internal circuit when supplied at **rated voltage** and under the most onerous combination of conditions of operation within equipment rating.

2) Material group IIIb is not recommended for application in **pollution degree** 3 above 630 V.

3) Provisional data based on extrapolation. Technical committees who have other information based on experience may use their dimensions.

4) The values given in brackets may be applied to reduce the creepage distance in case of using a rib (see 5.3.3.7).

NOTE The high precision for **creepage distances** given in this table does not mean that the uncertainty of measurement has to be in the same order of magnitude.

2155

2156 **Table F.6 – Test voltages for verifying clearances at different altitudes**2157 The voltage values of Table F.6 apply for the verification of **clearances** only.

Rated impulse withstand voltage $\hat{U}$ kV	Impulse test voltage at sea level $\hat{U}$ kV	Impulse test voltage at 200 m altitude $\hat{U}$ kV	Impulse test voltage at 500 m altitude $\hat{U}$ kV
0,33	0,357	0,355	0,350
0,5	0,541	0,537	0,531
0,8	0,934	0,920	0,899
1,5	1,751	1,725	1,685
2,5	2,920	2,874	2,808
4,0	4,923	4,824	4,675
6,0	7,385	7,236	7,013
8,0	9,847	9,648	9,350
12,0	14,770	14,471	14,025

NOTE 1 Explanations concerning the influencing factors (air pressure, altitude, temperature, humidity) with respect to electric strength of **clearances** are given in 4.6.5.

NOTE 2 When **testing clearances**, associated **solid insulation** will be subjected to the **test** voltage. As the impulse **test** voltage of Table F.6 is increased with respect to the **rated impulse withstand voltage**, **solid insulation** will have to be designed accordingly. This results in an increased impulse withstand capability of the **solid insulation**.

2158

2159

**Table F.7 – Severities for conditioning of solid insulation**

Test	Temperature °C	Relative humidity %	Time h	Number of cycles
a) Dry heat	+55	–	48	1
b) Dry heat cycle	–10 to +55	–	Cycle duration 24	3
c) Thermal shock (rapid change of temperature)	–10 to +55	–	2)	
d) Damp heat	30/40 <sup>1)</sup>	93	96	1

<sup>1)</sup> Standard temperature of damp heat **test** appears in IEC 60068-2-78.

<sup>2)</sup> Duration of the temperature change depends on the thermal time constant of the **test** specimen, see IEC 60068-2-14.

2160 NOTE For the damp heat **test** 25 °C is still used in some product standards.

2161

2162  
2163**Table F.8 – Clearances to withstand steady-state peak voltages, temporary overvoltages or recurring peak voltages****Table F.8a – Dimensioning of clearances to withstand steady-state peak voltages, temporary overvoltages or recurring peak voltages**

Voltage <sup>1)</sup> (peak value) <sup>2)</sup> kV	Minimum clearances in air up to 2 000 m above sea level	
	Case A Inhomogeneous field conditions (see 3.1.29) mm	Case B Homogeneous field conditions (see 3.1.28) mm
0,04	0,001 <sup>3)</sup>	0,001 <sup>3)</sup>
0,06	0,002 <sup>3)</sup>	0,002 <sup>3)</sup>
0,1	0,003 <sup>3)</sup>	0,003 <sup>3)</sup>
0,12	0,004 <sup>3)</sup>	0,004 <sup>3)</sup>
0,15	0,005 <sup>3)</sup>	0,005 <sup>3)</sup>
0,20	0,006 <sup>3)</sup>	0,006 <sup>3)</sup>
0,25	0,008 <sup>3)</sup>	0,008 <sup>3)</sup>
0,33	0,01	0,01
0,4	0,02	0,02
0,5	0,04	0,04
0,6	0,06	0,06
0,8	0,13	0,1
1,0	0,26	0,15
1,2	0,42	0,2
1,5	0,76	0,3
2,0	1,27	0,45
2,5	1,8	0,6
3,0	2,4	0,8
4,0	3,8	1,2
5,0	5,7	1,5
6,0	7,9	2
8,0	11,0	3
10	15,2	3,5
12	19	4,5
15	25	5,5
20	34	8
25	44	10
30	55	12,5
40	77	17
50	100	22
60		27
80		35
100		45

1) The **clearances** for other voltages are obtained by interpolation.  
2) See Figure 1 for **recurring peak voltage**.  
3) These values are based on experimental data obtained at atmospheric pressure.

**Table F.8b – Additional information concerning the dimensioning of clearances to avoid partial discharge**

Voltage <sup>1)</sup> (peak value) <sup>2)</sup> kV	Minimum clearances in air up to 2 000 m above sea level
	Case A Inhomogeneous field conditions (see 3.1.29) mm
0,04	As specified for Case A in Table F.8a
0,06	
0,1	
0,12	
0,15	
0,2	
0,25	
0,33	
0,4	
0,5	
0,6	
0,8	
1,0	
1,2	
1,5	
2,0	
2,5	
3,0	3,2
4,0	11
5,0	24
6,0	64
8,0	184
10	290
12	320
15	3)
20	
25	
30	
40	
50	
60	
80	
100	

1) The **clearances** for other voltages are obtained by interpolation.  
2) See Figure 1 for **recurring peak voltage**.  
3) Dimensioning without **partial discharge** is not possible under **inhomogeneous field** conditions.

2164  
2165  
2166  
2167  
2168  
2169

NOTE If clearances are stressed with **steady-state peak voltages** of 2,5 kV and above, dimensioning according to the breakdown values in Table F.8a cannot provide operation without corona (**partial discharges**), especially for **inhomogeneous fields**. In order to provide corona-free operation, it is either necessary to use larger **clearances**, as given in Table F.8b, or to improve the field distribution.

2170

**Table F.9 – Altitude correction factors**

<b>Altitude m</b>	<b>Factor <math>k_d</math> for distance correction</b>
0	0,784
200	0,803
500	0,833
1 000	0,844
2 000	1

2171

2172

2173  
2174  
2175  
2176  
2177

## Annex G (informative)

### Determination of clearance distances according to 5.2

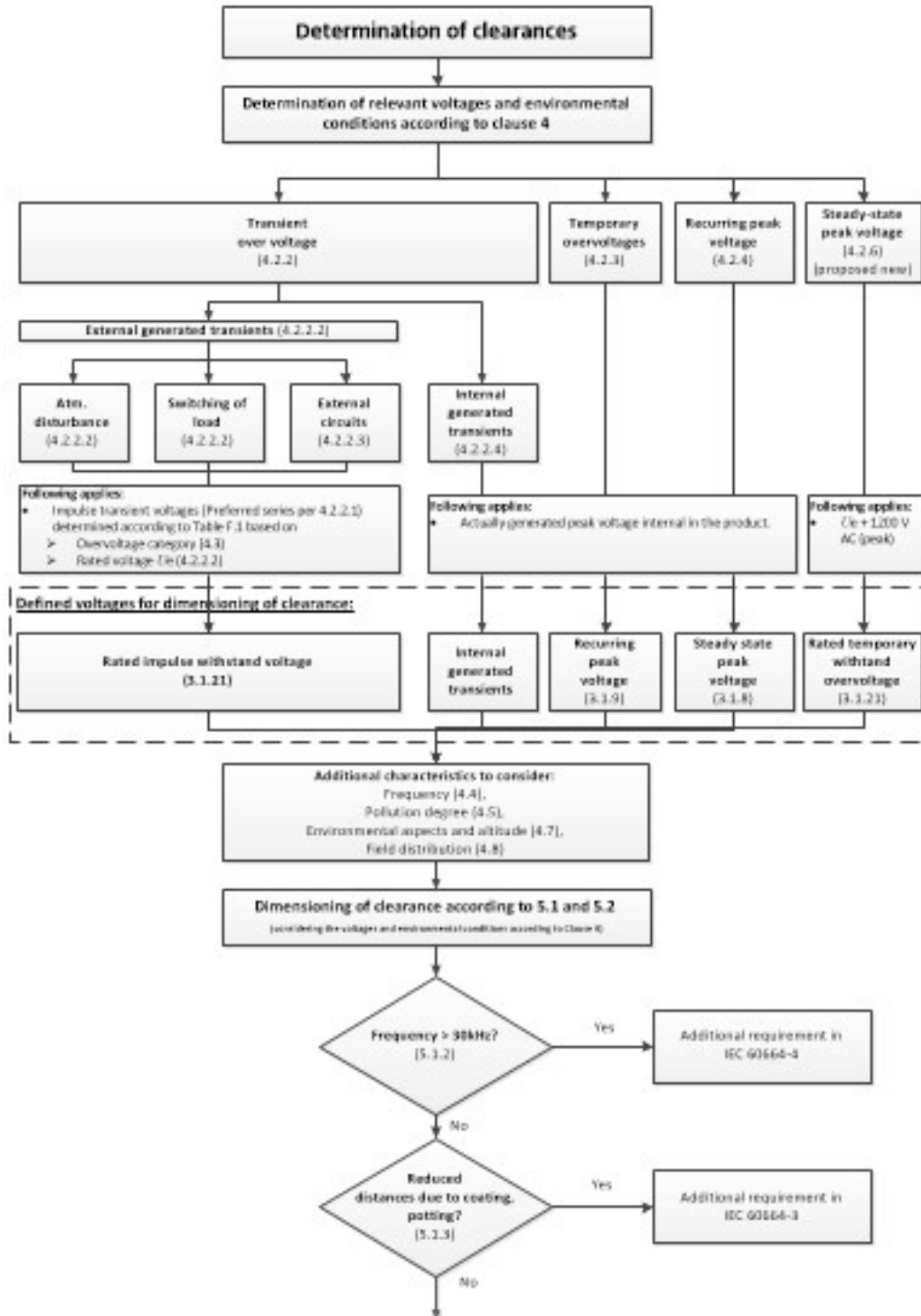

2178  
2179  
2180  
2181

Figure G.1 – Determination of clearance distances according to 5.2  
(continuation below)

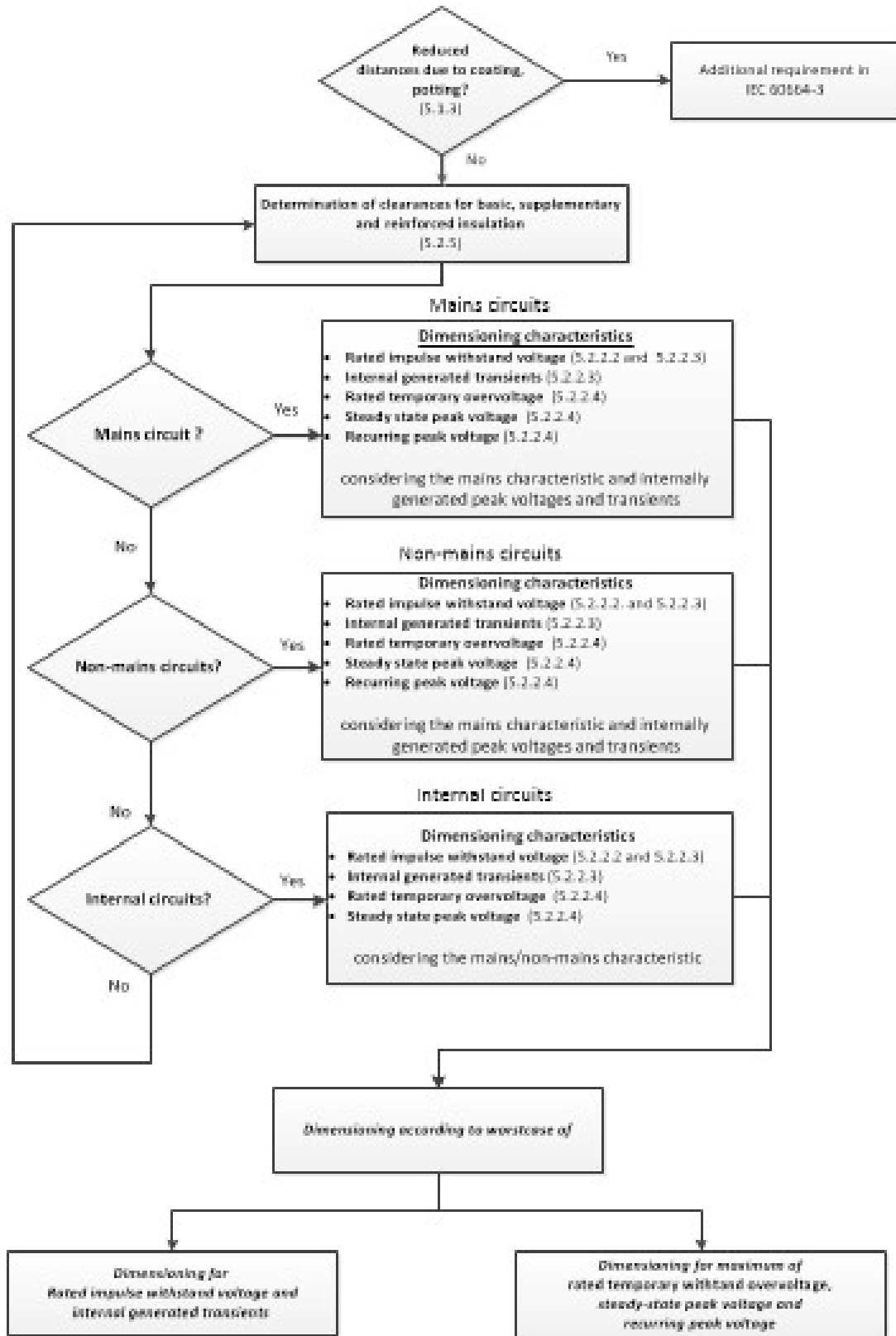

2182

2183

2184

2185

2186

**Figure G.1 – Determination of clearance distances according to 5.2**  
(continuation below)

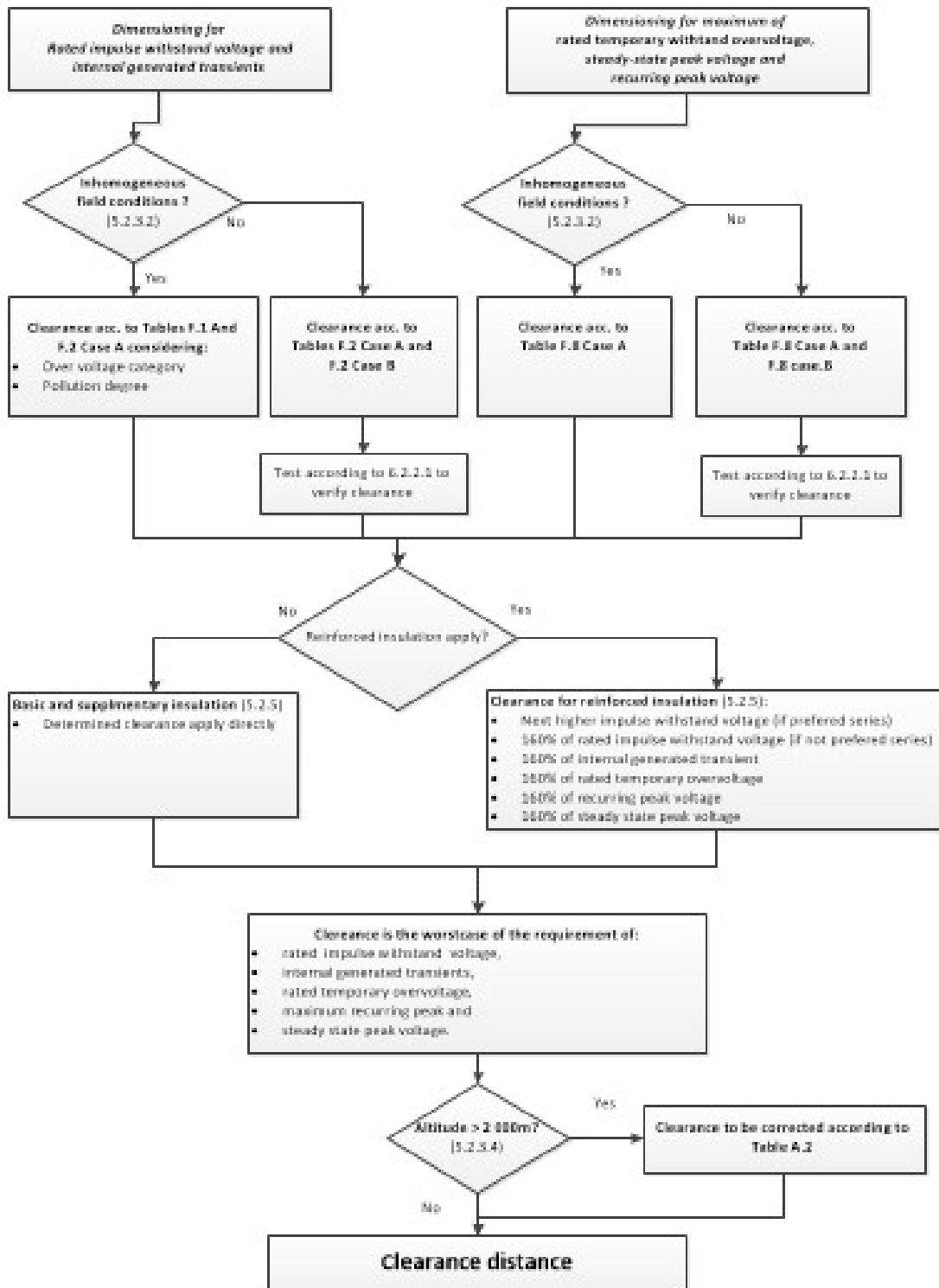

2187

2188

2189

2190

Figure G.1 – Determination of clearance distances according to 5.2  
(end)

2191  
2192  
2193  
2194  
2195

## Annex H (informative)

### Determination of creepage distances according to 5.3

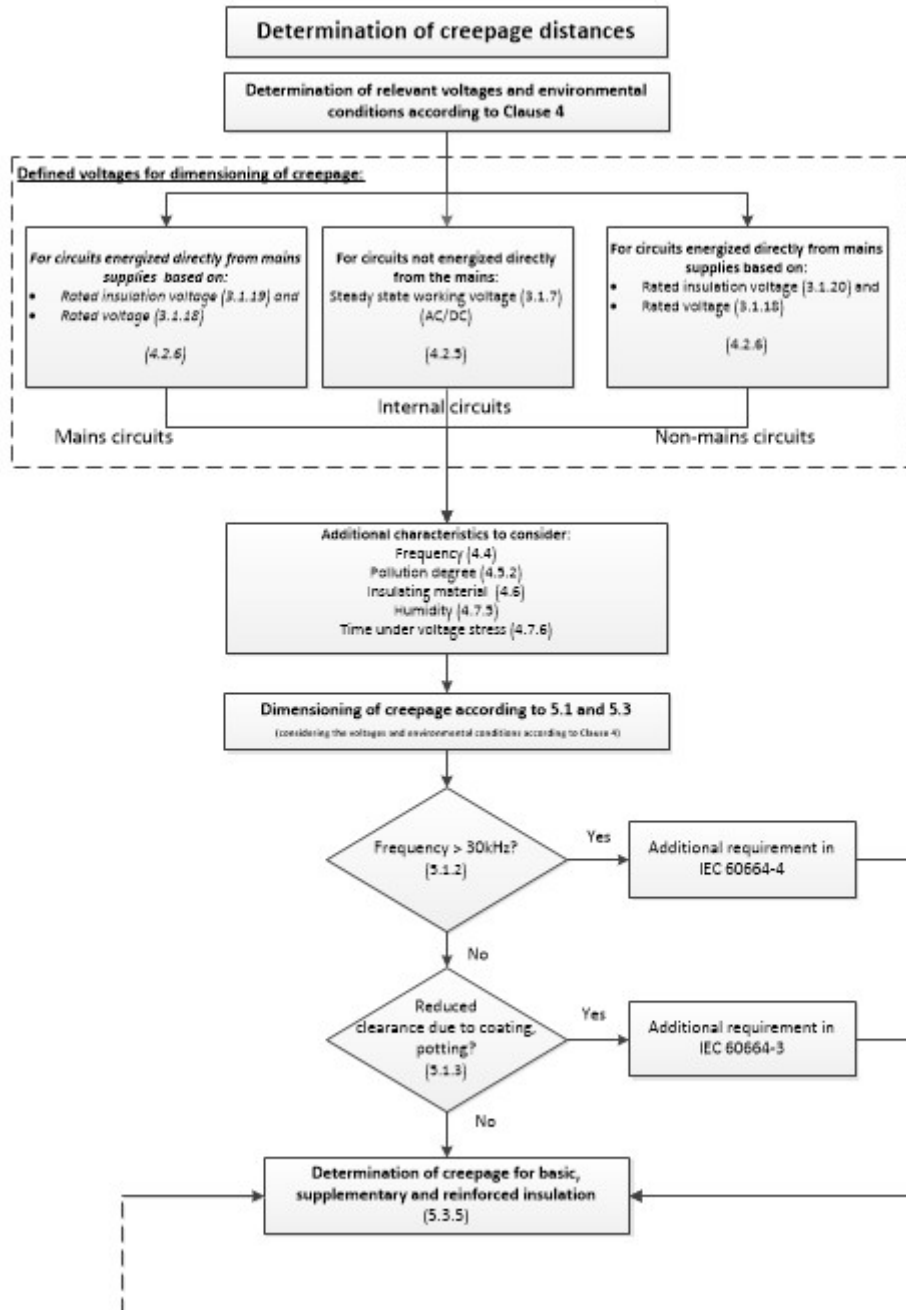

2196  
2197  
2198  
2199

Figure H.1 – Determination of creepage distances according to 5.3  
(continuation below)

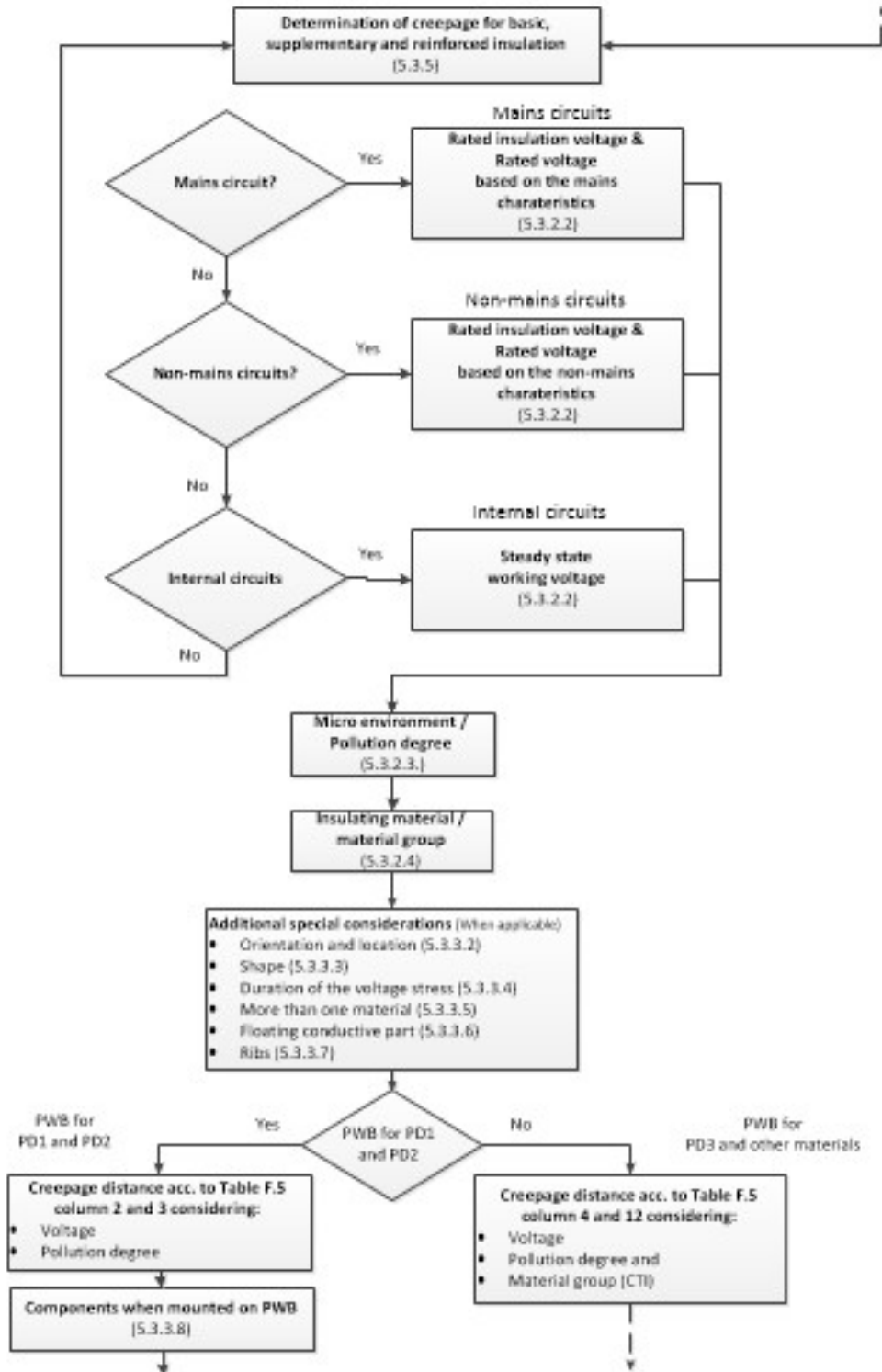

Figure H.1 – Determination of creepage distances according to 5.3  
(continuation)

2200

2201

2202

2203

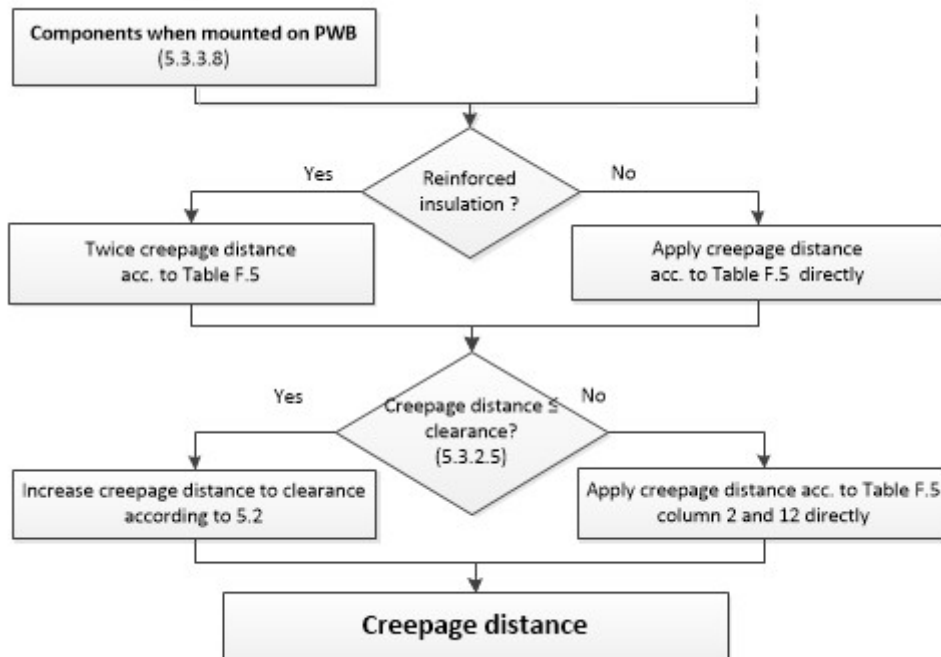

2204

2205

2206

2207

**Figure H.1 – Determination of creepage distances according to 5.3**  
(end)

2208

## Bibliography

- 2209 IEC 60050-151:2001, *International Electrotechnical Vocabulary (IEV) – Part 151: Electrical*  
2210 *and magnetic devices*
- 2211 IEC 60050-151:2001/AMD1:2013  
2212 IEC 60050-151:2001/AMD2:2014
- 2213 IEC 60050-212:2010, *International Electrotechnical Vocabulary (IEV) – Part 212: Electrical*  
2214 *insulating solids, liquids and gases*
- 2215 IEC 60050-212:2010/AMD1 2015  
2216 IEC 60050-212:2010/AMD2 2015
- 2217 IEC 60050-312:2015, *International Electrotechnical Vocabulary (IEV) – Part 312: General*  
2218 *terms relating to electrical measurements*
- 2219 IEC 60050-442:1998, *International Electrotechnical Vocabulary (IEV) – Part 442: Electrical*  
2220 *accessories*
- 2221 IEC 60050-442:1998/AMD1 2015  
2222 IEC 60050-442:1998/AMD2 2015
- 2223 IEC 60050-581:2008, *International Electrotechnical Vocabulary (IEV) – Part 581:*  
2224 *Electromechanical components for electronic equipment*
- 2225 IEC 60050-601:1985, *International Electrotechnical Vocabulary (IEV) – Chapter 601:*  
2226 *Generation, transmission and distribution of electricity – General*  
2227 IEC 60050-601:1985/AMD1:1998
- 2228 IEC 60050-604:1987, *International Electrotechnical Vocabulary (IEV) – Chapter 604:*  
2229 *Generation, transmission and distribution of electricity – Operation*
- 2230 IEC 60050-604:1987/AMD1 1998  
2231 IEC 60050-604:1987/AMD2 2015
- 2232 IEC 60050-614:2016, *International Electrotechnical Vocabulary (IEV) – Part 614: Generation,*  
2233 *transmission and distribution of electricity - Operation*
- 2234 IEC 60050-826:2004, *International Electrotechnical Vocabulary (IEV) – Part 826: Electrical*  
2235 *installations*
- 2236 IEC 60050-851:2008, *International Electrotechnical Vocabulary (IEV) – Part 851: Electric*  
2237 *welding*  
2238 IEC 60050-851:2008/AMD1:2014
- 2239 IEC 60050-903:2013, *International Electrotechnical Vocabulary (IEV) – Part 903: Risk*  
2240 *assessment*
- 2241 IEC 60050-903:2013/AMD1 2014  
2242 IEC 60050-903:2013/AMD2 2015
- 2243 IEC 60529: Degrees of protection provided by enclosures (IP Code)
- 2244 IEC/TS 61934:2011, *Electrical insulating materials and systems - Electrical measurement of*  
2245 *partial discharges (PD) under short rise time and repetitive voltage impulses*
- 2246 ISO/IEC Guide 2:1996, Standardization and related activities – General vocabulary
- 2247 [1] PFEIFFER, W. “Die Stoßspannungsfestigkeit von Luftstrecken kleiner Schlagweite“.  
2248 *Elektrotechnische Zeitschrift B*; Vol.28(1976), pp300-302
- 2249 [2] HERMSTEIN, W. Bemessung von Luftstrecken, Insbesondere für 50 Hz-  
2250 *Wechselspannung*, *Elektrotechnische Zeitschrift*; Vol.90(1969), pp251-255
- 2251 [3] DAKIN, T., LUXA, G., OPPERMANN, G., VIGREUX, J., WIND, G. WINKELNKEMPER,  
2252 H. “Breakdown of gases in uniform fields, paschen curves for nitrogen, air and sulfur  
2253 hexafluoride”; *Electra* (issued by CIGRE), Vol.32(1974), pp61-82.

2254

2255