

Features

- Compatible with MCS-51™ Products
- 4K Bytes of In-System Reprogrammable Flash Memory
 - Endurance: 1,000 Write/Erase Cycles
- Fully Static Operation: 0 Hz to 24 MHz
- Three-level Program Memory Lock
- 128 x 8-bit Internal RAM
- 32 Programmable I/O Lines
- Two 16-bit Timer/Counters
- Six Interrupt Sources
- Programmable Serial Channel
- Low-power Idle and Power-down Modes

Description

The AT89C51 is a low-power, high-performance CMOS 8-bit microcomputer with 4K bytes of Flash programmable and erasable read only memory (PEROM). The device is manufactured using Atmel's high-density nonvolatile memory technology and is compatible with the industry-standard MCS-51 instruction set and pinout. The on-chip Flash allows the program memory to be reprogrammed in-system or by a conventional nonvolatile memory programmer. By combining a versatile 8-bit CPU with Flash on a monolithic chip, the Atmel AT89C51 is a powerful microcomputer which provides a highly-flexible and cost-effective solution to many embedded control applications.

Pin Configurations

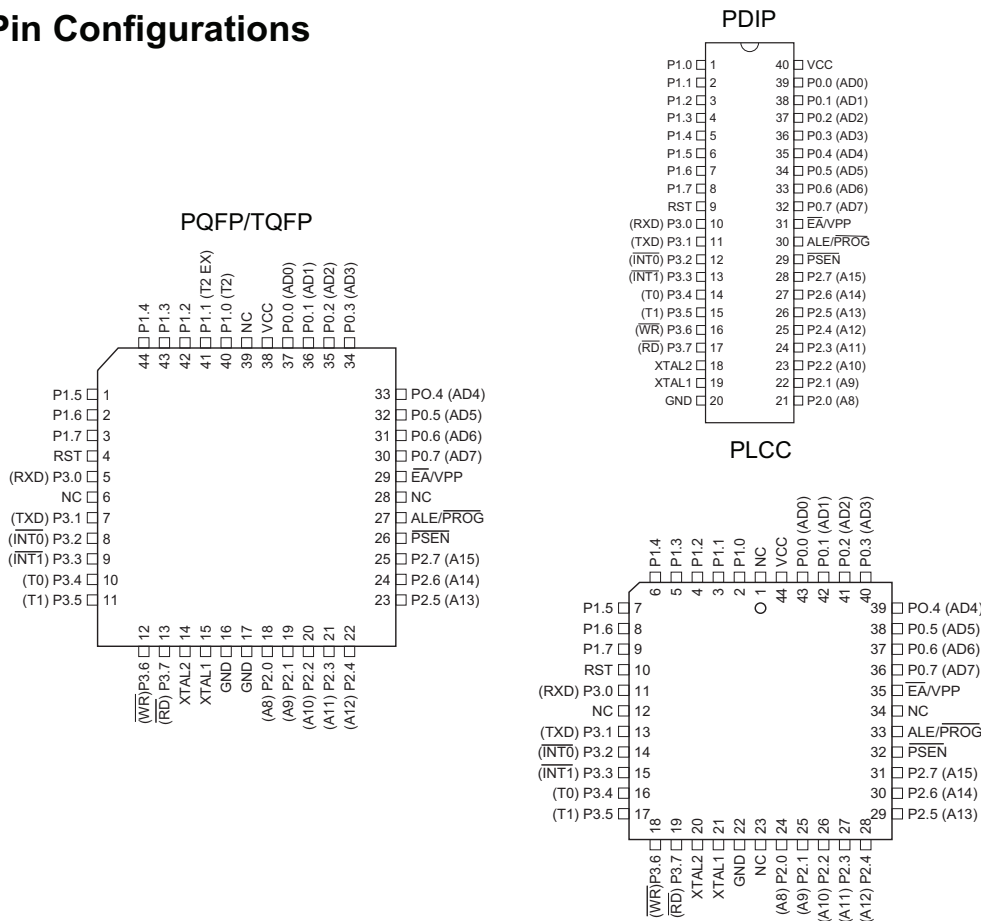

8-bit Microcontroller with 4K Bytes Flash

AT89C51

**Not Recommended
for New Designs.
Use AT89S51.**



Block Diagram

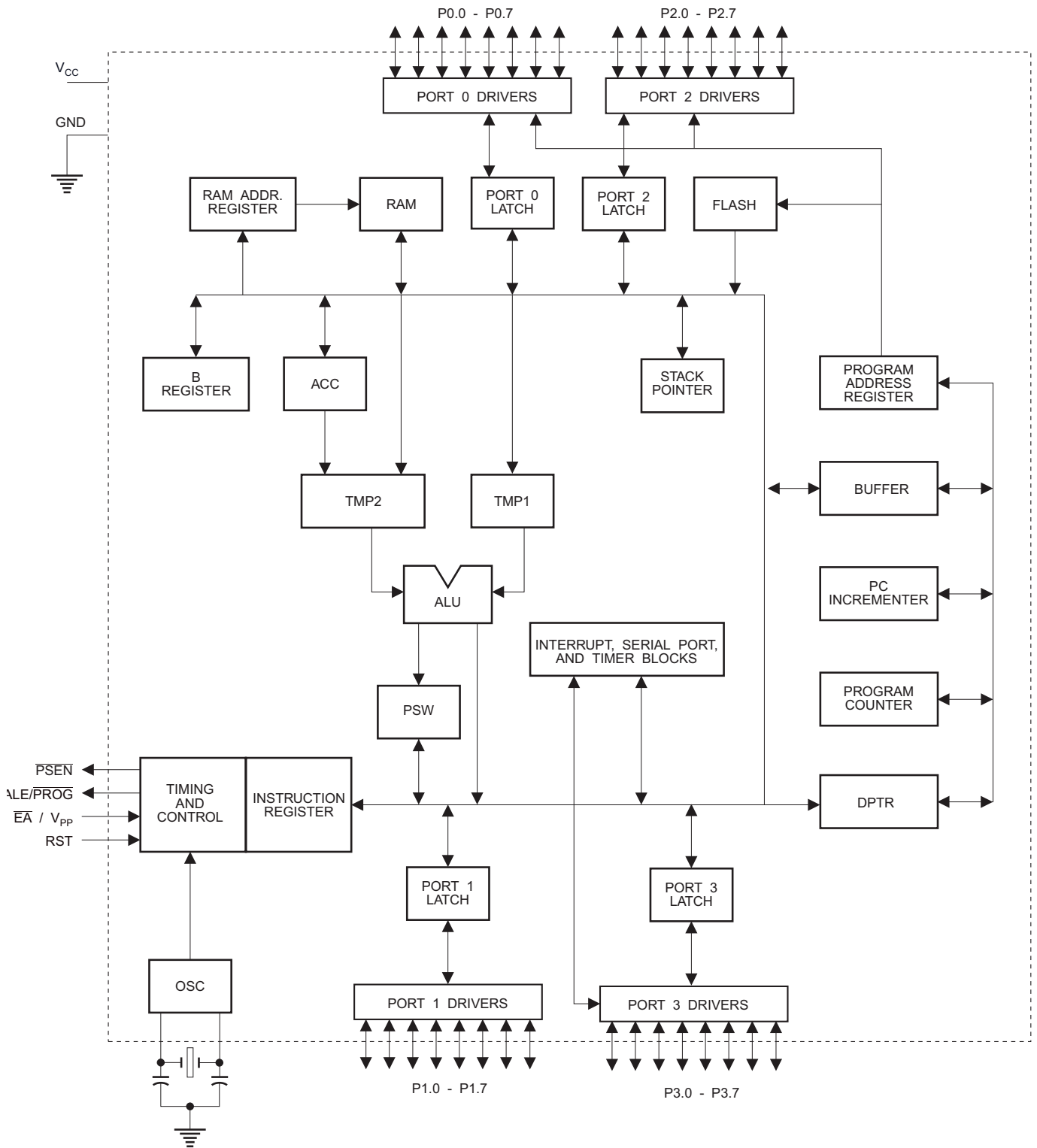

The AT89C51 provides the following standard features: 4K bytes of Flash, 128 bytes of RAM, 32 I/O lines, two 16-bit timer/counters, a five vector two-level interrupt architecture, a full duplex serial port, on-chip oscillator and clock circuitry. In addition, the AT89C51 is designed with static logic for operation down to zero frequency and supports two software selectable power saving modes. The Idle Mode stops the CPU while allowing the RAM, timer/counters, serial port and interrupt system to continue functioning. The Power-down Mode saves the RAM contents but freezes the oscillator disabling all other chip functions until the next hardware reset.

Pin Description

VCC

Supply voltage.

GND

Ground.

Port 0

Port 0 is an 8-bit open-drain bi-directional I/O port. As an output port, each pin can sink eight TTL inputs. When 1s are written to port 0 pins, the pins can be used as high-impedance inputs.

Port 0 may also be configured to be the multiplexed low-order address/data bus during accesses to external program and data memory. In this mode P0 has internal pullups.

Port 0 also receives the code bytes during Flash programming, and outputs the code bytes during program verification. External pullups are required during program verification.

Port 1

Port 1 is an 8-bit bi-directional I/O port with internal pullups. The Port 1 output buffers can sink/source four TTL inputs. When 1s are written to Port 1 pins they are pulled high by the internal pullups and can be used as inputs. As inputs, Port 1 pins that are externally being pulled low will source current (I_{IL}) because of the internal pullups.

Port 1 also receives the low-order address bytes during Flash programming and verification.

Port 2

Port 2 is an 8-bit bi-directional I/O port with internal pullups. The Port 2 output buffers can sink/source four TTL inputs. When 1s are written to Port 2 pins they are pulled high by the internal pullups and can be used as inputs. As inputs,

Port 2 pins that are externally being pulled low will source current (I_{IL}) because of the internal pullups.

Port 2 emits the high-order address byte during fetches from external program memory and during accesses to external data memory that use 16-bit addresses (MOVX @ DPTR). In this application, it uses strong internal pullups when emitting 1s. During accesses to external data memory that use 8-bit addresses (MOVX @ RI), Port 2 emits the contents of the P2 Special Function Register.

Port 2 also receives the high-order address bits and some control signals during Flash programming and verification.

Port 3

Port 3 is an 8-bit bi-directional I/O port with internal pullups. The Port 3 output buffers can sink/source four TTL inputs. When 1s are written to Port 3 pins they are pulled high by the internal pullups and can be used as inputs. As inputs, Port 3 pins that are externally being pulled low will source current (I_{IL}) because of the pullups.

Port 3 also serves the functions of various special features of the AT89C51 as listed below:

Port Pin	Alternate Functions
P3.0	RXD (serial input port)
P3.1	TXD (serial output port)
P3.2	$\overline{INT0}$ (external interrupt 0)
P3.3	$\overline{INT1}$ (external interrupt 1)
P3.4	T0 (timer 0 external input)
P3.5	T1 (timer 1 external input)
P3.6	\overline{WR} (external data memory write strobe)
P3.7	\overline{RD} (external data memory read strobe)

Port 3 also receives some control signals for Flash programming and verification.

RST

Reset input. A high on this pin for two machine cycles while the oscillator is running resets the device.

ALE/ \overline{PROG}

Address Latch Enable output pulse for latching the low byte of the address during accesses to external memory. This pin is also the program pulse input (\overline{PROG}) during Flash programming.

In normal operation ALE is emitted at a constant rate of 1/6 the oscillator frequency, and may be used for external timing or clocking purposes. Note, however, that one ALE

pulse is skipped during each access to external Data Memory.

If desired, ALE operation can be disabled by setting bit 0 of SFR location 8EH. With the bit set, ALE is active only during a MOVX or MOVC instruction. Otherwise, the pin is weakly pulled high. Setting the ALE-disable bit has no effect if the microcontroller is in external execution mode.

$\overline{\text{PSEN}}$

Program Store Enable is the read strobe to external program memory.

When the AT89C51 is executing code from external program memory, $\overline{\text{PSEN}}$ is activated twice each machine cycle, except that two $\overline{\text{PSEN}}$ activations are skipped during each access to external data memory.

$\overline{\text{EA/VPP}}$

External Access Enable. $\overline{\text{EA}}$ must be strapped to GND in order to enable the device to fetch code from external program memory locations starting at 0000H up to FFFFH. Note, however, that if lock bit 1 is programmed, $\overline{\text{EA}}$ will be internally latched on reset.

$\overline{\text{EA}}$ should be strapped to V_{CC} for internal program executions.

This pin also receives the 12-volt programming enable voltage (V_{PP}) during Flash programming, for parts that require 12-volt V_{PP} .

XTAL1

Input to the inverting oscillator amplifier and input to the internal clock operating circuit.

XTAL2

Output from the inverting oscillator amplifier.

Oscillator Characteristics

XTAL1 and XTAL2 are the input and output, respectively, of an inverting amplifier which can be configured for use as an on-chip oscillator, as shown in Figure 1. Either a quartz crystal or ceramic resonator may be used. To drive the device from an external clock source, XTAL2 should be left

unconnected while XTAL1 is driven as shown in Figure 2. There are no requirements on the duty cycle of the external clock signal, since the input to the internal clocking circuitry is through a divide-by-two flip-flop, but minimum and maximum voltage high and low time specifications must be observed.

Idle Mode

In idle mode, the CPU puts itself to sleep while all the on-chip peripherals remain active. The mode is invoked by software. The content of the on-chip RAM and all the special functions registers remain unchanged during this mode. The idle mode can be terminated by any enabled interrupt or by a hardware reset.

It should be noted that when idle is terminated by a hardware reset, the device normally resumes program execution, from where it left off, up to two machine cycles before the internal reset algorithm takes control. On-chip hardware inhibits access to internal RAM in this event, but access to the port pins is not inhibited. To eliminate the possibility of an unexpected write to a port pin when Idle is terminated by reset, the instruction following the one that invokes Idle should not be one that writes to a port pin or to external memory.

Figure 1. Oscillator Connections

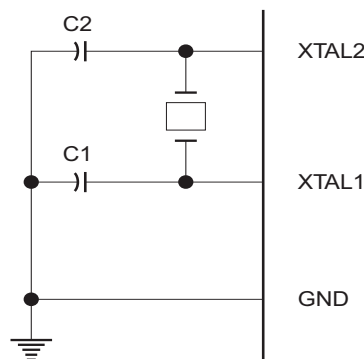

Note: C1, C2 = 30 pF \pm 10 pF for Crystals
= 40 pF \pm 10 pF for Ceramic Resonators

Status of External Pins During Idle and Power-down Modes

Mode	Program Memory	ALE	$\overline{\text{PSEN}}$	PORT0	PORT1	PORT2	PORT3
Idle	Internal	1	1	Data	Data	Data	Data
Idle	External	1	1	Float	Data	Address	Data
Power-down	Internal	0	0	Data	Data	Data	Data
Power-down	External	0	0	Float	Data	Data	Data

Figure 2. External Clock Drive Configuration

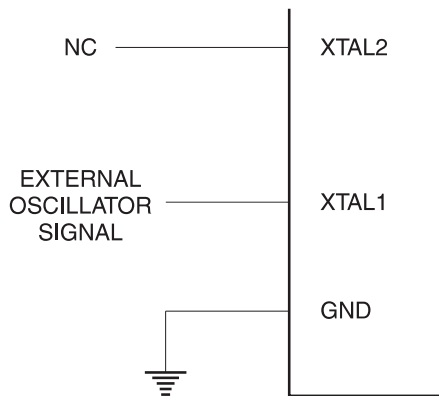

Power-down Mode

In the power-down mode, the oscillator is stopped, and the instruction that invokes power-down is the last instruction executed. The on-chip RAM and Special Function Regis-

ters retain their values until the power-down mode is terminated. The only exit from power-down is a hardware reset. Reset redefines the SFRs but does not change the on-chip RAM. The reset should not be activated before V_{CC} is restored to its normal operating level and must be held active long enough to allow the oscillator to restart and stabilize.

Program Memory Lock Bits

On the chip are three lock bits which can be left unprogrammed (U) or can be programmed (P) to obtain the additional features listed in the table below.

When lock bit 1 is programmed, the logic level at the \overline{EA} pin is sampled and latched during reset. If the device is powered up without a reset, the latch initializes to a random value, and holds that value until reset is activated. It is necessary that the latched value of \overline{EA} be in agreement with the current logic level at that pin in order for the device to function properly.

Lock Bit Protection Modes

	Program Lock Bits			Protection Type
	LB1	LB2	LB3	
1	U	U	U	No program lock features
2	P	U	U	MOV _C instructions executed from external program memory are disabled from fetching code bytes from internal memory, \overline{EA} is sampled and latched on reset, and further programming of the Flash is disabled
3	P	P	U	Same as mode 2, also verify is disabled
4	P	P	P	Same as mode 3, also external execution is disabled



Programming the Flash

The AT89C51 is normally shipped with the on-chip Flash memory array in the erased state (that is, contents = FFH) and ready to be programmed. The programming interface accepts either a high-voltage (12-volt) or a low-voltage (V_{CC}) program enable signal. The low-voltage programming mode provides a convenient way to program the AT89C51 inside the user's system, while the high-voltage programming mode is compatible with conventional third-party Flash or EPROM programmers.

The AT89C51 is shipped with either the high-voltage or low-voltage programming mode enabled. The respective top-side marking and device signature codes are listed in the following table.

	$V_{PP} = 12V$	$V_{PP} = 5V$
Top-side Mark	AT89C51 xxxx yyww	AT89C51 xxxx-5 yyww
Signature	(030H) = 1EH (031H) = 51H (032H) = F FH	(030H) = 1EH (031H) = 51H (032H) = 05H

The AT89C51 code memory array is programmed byte-by-byte in either programming mode. *To program any non-blank byte in the on-chip Flash Memory, the entire memory must be erased using the Chip Erase Mode.*

Programming Algorithm: Before programming the AT89C51, the address, data and control signals should be set up according to the Flash programming mode table and Figure 3 and Figure 4. To program the AT89C51, take the following steps.

1. Input the desired memory location on the address lines.
2. Input the appropriate data byte on the data lines.
3. Activate the correct combination of control signals.
4. Raise \overline{EA}/V_{PP} to 12V for the high-voltage programming mode.
5. Pulse ALE/\overline{PROG} once to program a byte in the Flash array or the lock bits. The byte-write cycle is self-timed and typically takes no more than 1.5 ms. Repeat steps 1 through 5, changing the address

and data for the entire array or until the end of the object file is reached.

Data Polling: The AT89C51 features \overline{Data} Polling to indicate the end of a write cycle. During a write cycle, an attempted read of the last byte written will result in the complement of the written datum on PO.7. Once the write cycle has been completed, true data are valid on all outputs, and the next cycle may begin. \overline{Data} Polling may begin any time after a write cycle has been initiated.

Ready/Busy: The progress of byte programming can also be monitored by the RDY/\overline{BSY} output signal. P3.4 is pulled low after ALE goes high during programming to indicate BUSY. P3.4 is pulled high again when programming is done to indicate READY.

Program Verify: If lock bits LB1 and LB2 have not been programmed, the programmed code data can be read back via the address and data lines for verification. The lock bits cannot be verified directly. Verification of the lock bits is achieved by observing that their features are enabled.

Chip Erase: The entire Flash array is erased electrically by using the proper combination of control signals and by holding ALE/ \overline{PROG} low for 10 ms. The code array is written with all "1"s. The chip erase operation must be executed before the code memory can be re-programmed.

Reading the Signature Bytes: The signature bytes are read by the same procedure as a normal verification of locations 030H, 031H, and 032H, except that P3.6 and P3.7 must be pulled to a logic low. The values returned are as follows.

- (030H) = 1EH indicates manufactured by Atmel
- (031H) = 51H indicates 89C51
- (032H) = FFH indicates 12V programming
- (032H) = 05H indicates 5V programming

Programming Interface

Every code byte in the Flash array can be written and the entire array can be erased by using the appropriate combination of control signals. The write operation cycle is self-timed and once initiated, will automatically time itself to completion.

All major programming vendors offer worldwide support for the Atmel microcontroller series. Please contact your local programming vendor for the appropriate software revision.

Flash Programming Modes

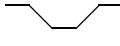
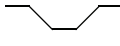
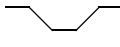
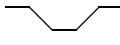
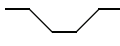
Mode	RST	PSEN	ALE/PROG	EA/V _{PP}	P2.6	P2.7	P3.6	P3.7
Write Code Data	H	L		H/12V	L	H	H	H
Read Code Data	H	L	H	H	L	L	H	H
Write Lock	H	L		H/12V	H	H	H	H
								
								
Chip Erase	H	L	 (1)	H/12V	H	L	L	L
Read Signature Byte	H	L	H	H	L	L	L	L

Note: 1. Chip Erase requires a 10 ms PROG pulse.

Figure 3. Programming the Flash

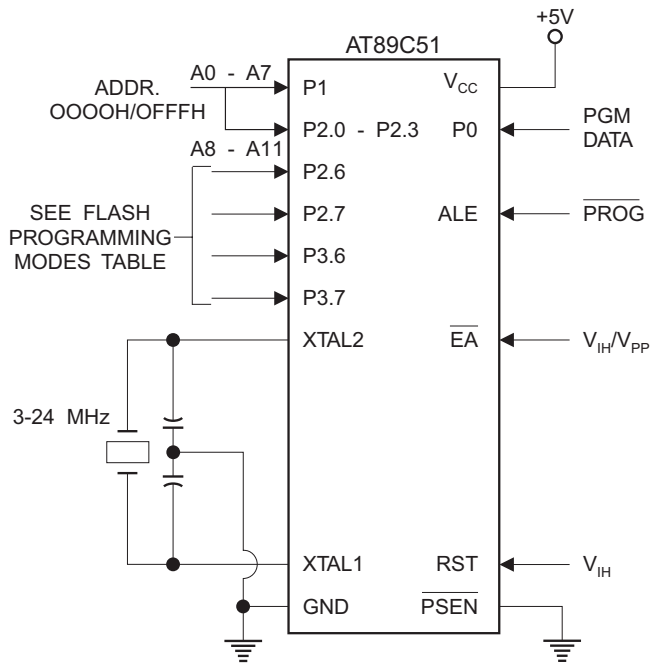
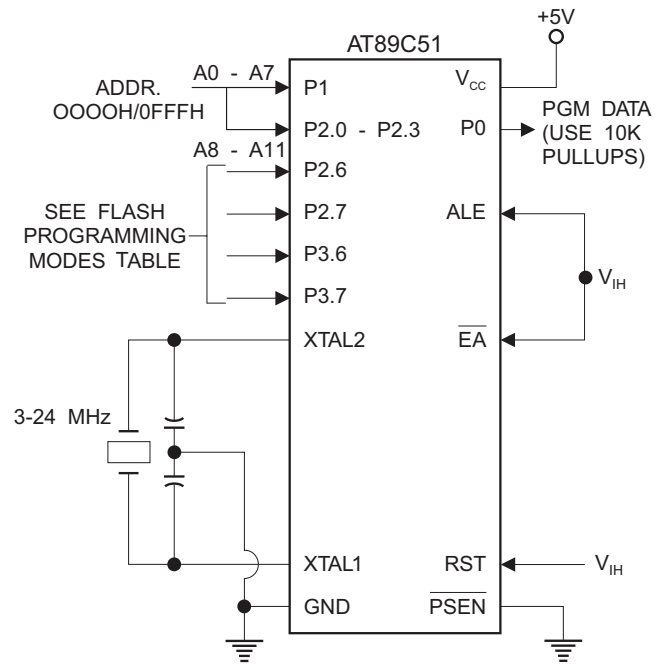
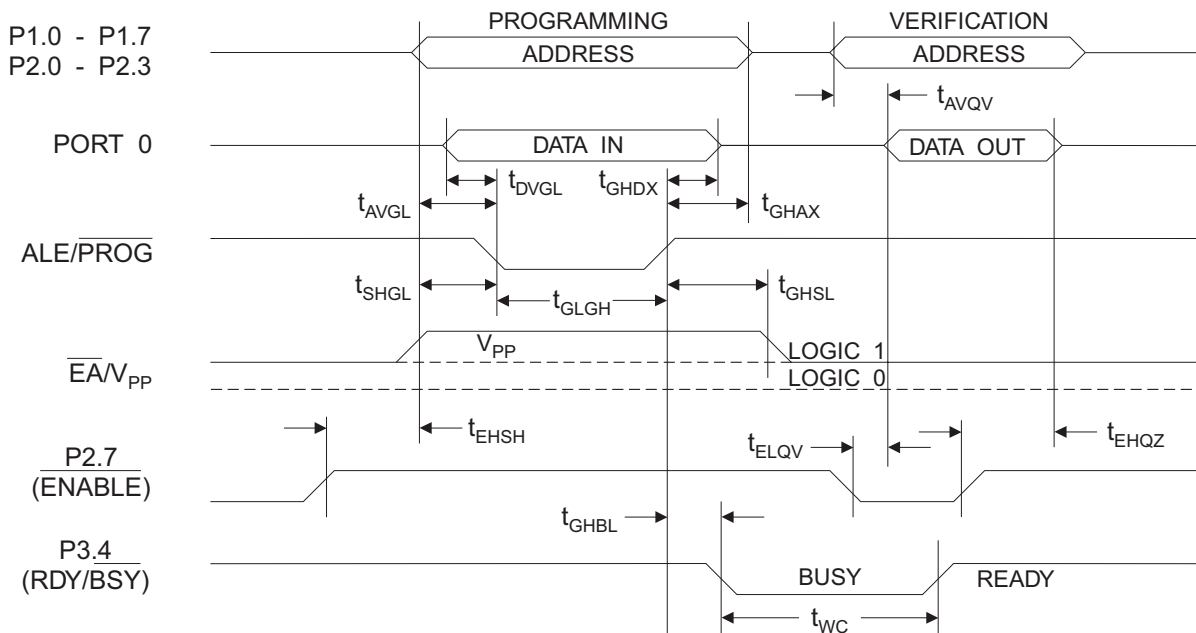

Figure 4. Verifying the Flash





Flash Programming and Verification Waveforms - High-voltage Mode ($V_{PP} = 12V$)



Flash Programming and Verification Waveforms - Low-voltage Mode ($V_{PP} = 5V$)

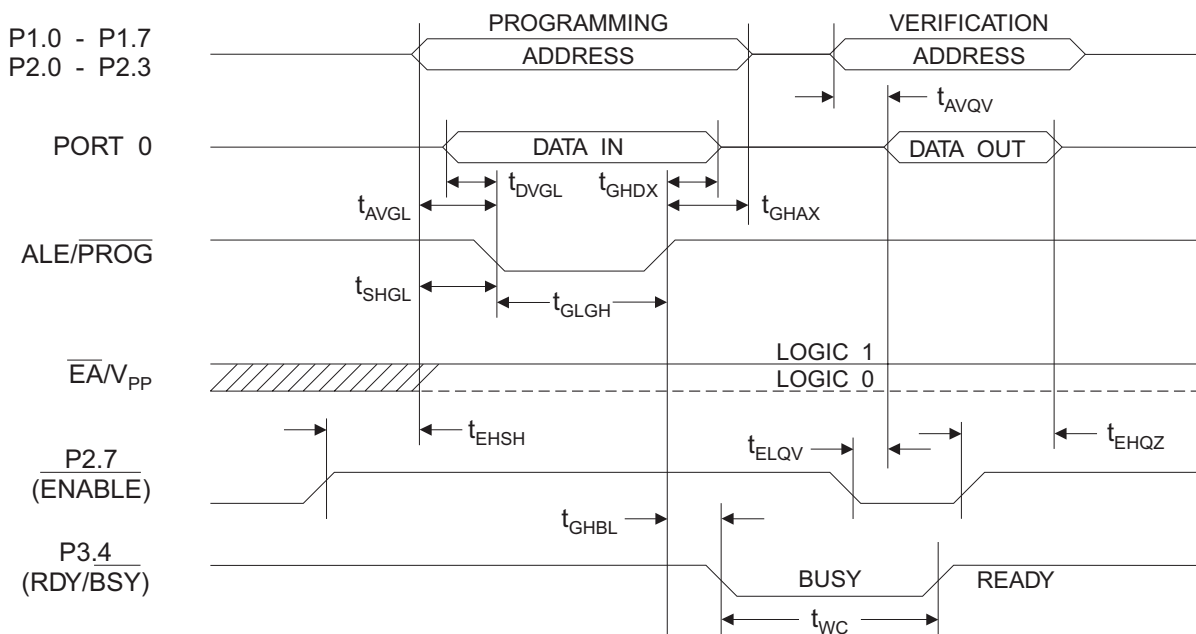

Flash Programming and Verification Characteristics

$T_A = 0^\circ\text{C}$ to 70°C , $V_{CC} = 5.0 \pm 10\%$

Symbol	Parameter	Min	Max	Units
$V_{PP}^{(1)}$	Programming Enable Voltage	11.5	12.5	V
$I_{PP}^{(1)}$	Programming Enable Current		1.0	mA
$1/t_{CLCL}$	Oscillator Frequency	3	24	MHz
t_{AVGL}	Address Setup to \overline{PROG} Low	$48t_{CLCL}$		
t_{GHAX}	Address Hold after \overline{PROG}	$48t_{CLCL}$		
t_{DVGL}	Data Setup to \overline{PROG} Low	$48t_{CLCL}$		
t_{GHDX}	Data Hold after \overline{PROG}	$48t_{CLCL}$		
t_{EHS}	P2.7 (\overline{ENABLE}) High to V_{PP}	$48t_{CLCL}$		
t_{SHGL}	V_{PP} Setup to \overline{PROG} Low	10		μs
$t_{GHSL}^{(1)}$	V_{PP} Hold after \overline{PROG}	10		μs
t_{GLGH}	\overline{PROG} Width	1	110	μs
t_{AVQV}	Address to Data Valid		$48t_{CLCL}$	
t_{ELQV}	\overline{ENABLE} Low to Data Valid		$48t_{CLCL}$	
t_{EHQZ}	Data Float after \overline{ENABLE}	0	$48t_{CLCL}$	
t_{GHBL}	\overline{PROG} High to \overline{BUSY} Low		1.0	μs
t_{WC}	Byte Write Cycle Time		2.0	ms

Note: 1. Only used in 12-volt programming mode.



Absolute Maximum Ratings*

Operating Temperature.....	-55°C to +125°C
Storage Temperature.....	-65°C to +150°C
Voltage on Any Pin with Respect to Ground.....	-1.0V to +7.0V
Maximum Operating Voltage.....	6.6V
DC Output Current.....	15.0 mA

*NOTICE: Stresses beyond those listed under “Absolute Maximum Ratings” may cause permanent damage to the device. This is a stress rating only and functional operation of the device at these or any other conditions beyond those indicated in the operational sections of this specification is not implied. Exposure to absolute maximum rating conditions for extended periods may affect device reliability.

DC Characteristics

$T_A = -40^\circ\text{C}$ to 85°C , $V_{CC} = 5.0\text{V} \pm 20\%$ (unless otherwise noted)

Symbol	Parameter	Condition	Min	Max	Units
V_{IL}	Input Low-voltage	(Except \overline{EA})	-0.5	$0.2 V_{CC} - 0.1$	V
V_{IL1}	Input Low-voltage (\overline{EA})		-0.5	$0.2 V_{CC} - 0.3$	V
V_{IH}	Input High-voltage	(Except XTAL1, RST)	$0.2 V_{CC} + 0.9$	$V_{CC} + 0.5$	V
V_{IH1}	Input High-voltage	(XTAL1, RST)	$0.7 V_{CC}$	$V_{CC} + 0.5$	V
V_{OL}	Output Low-voltage ⁽¹⁾ (Ports 1,2,3)	$I_{OL} = 1.6 \text{ mA}$		0.45	V
V_{OL1}	Output Low-voltage ⁽¹⁾ (Port 0, ALE, \overline{PSEN})	$I_{OL} = 3.2 \text{ mA}$		0.45	V
V_{OH}	Output High-voltage (Ports 1,2,3, ALE, \overline{PSEN})	$I_{OH} = -60 \mu\text{A}$, $V_{CC} = 5\text{V} \pm 10\%$	2.4		V
		$I_{OH} = -25 \mu\text{A}$	$0.75 V_{CC}$		V
		$I_{OH} = -10 \mu\text{A}$	$0.9 V_{CC}$		V
V_{OH1}	Output High-voltage (Port 0 in External Bus Mode)	$I_{OH} = -800 \mu\text{A}$, $V_{CC} = 5\text{V} \pm 10\%$	2.4		V
		$I_{OH} = -300 \mu\text{A}$	$0.75 V_{CC}$		V
		$I_{OH} = -80 \mu\text{A}$	$0.9 V_{CC}$		V
I_{IL}	Logical 0 Input Current (Ports 1,2,3)	$V_{IN} = 0.45\text{V}$		-50	μA
I_{TL}	Logical 1 to 0 Transition Current (Ports 1,2,3)	$V_{IN} = 2\text{V}$, $V_{CC} = 5\text{V} \pm 10\%$		-650	μA
I_{LI}	Input Leakage Current (Port 0, \overline{EA})	$0.45 < V_{IN} < V_{CC}$		± 10	μA
RRST	Reset Pull-down Resistor		50	300	$\text{K}\Omega$
C_{IO}	Pin Capacitance	Test Freq. = 1 MHz, $T_A = 25^\circ\text{C}$		10	pF
I_{CC}	Power Supply Current	Active Mode, 12 MHz		20	mA
		Idle Mode, 12 MHz		5	mA
	Power-down Mode ⁽²⁾	$V_{CC} = 6\text{V}$		100	μA
		$V_{CC} = 3\text{V}$		40	μA

Notes: 1. Under steady state (non-transient) conditions, I_{OL} must be externally limited as follows:

- Maximum I_{OL} per port pin: 10 mA
- Maximum I_{OL} per 8-bit port: Port 0: 26 mA
- Ports 1, 2, 3: 15 mA
- Maximum total I_{OL} for all output pins: 71 mA

If I_{OL} exceeds the test condition, V_{OL} may exceed the related specification. Pins are not guaranteed to sink current greater than the listed test conditions.

- 2. Minimum V_{CC} for Power-down is 2V.

AC Characteristics

Under operating conditions, load capacitance for Port 0, ALE/ $\overline{\text{PROG}}$, and $\overline{\text{PSEN}}$ = 100 pF; load capacitance for all other outputs = 80 pF.

External Program and Data Memory Characteristics

Symbol	Parameter	12 MHz Oscillator		16 to 24 MHz Oscillator		Units
		Min	Max	Min	Max	
$1/t_{\text{CLCL}}$	Oscillator Frequency			0	24	MHz
t_{LHLL}	ALE Pulse Width	127		$2t_{\text{CLCL}}-40$		ns
t_{AVLL}	Address Valid to ALE Low	43		$t_{\text{CLCL}}-13$		ns
t_{LLAX}	Address Hold after ALE Low	48		$t_{\text{CLCL}}-20$		ns
t_{LLIV}	ALE Low to Valid Instruction In		233		$4t_{\text{CLCL}}-65$	ns
t_{LLPL}	ALE Low to $\overline{\text{PSEN}}$ Low	43		$t_{\text{CLCL}}-13$		ns
t_{PLPH}	$\overline{\text{PSEN}}$ Pulse Width	205		$3t_{\text{CLCL}}-20$		ns
t_{PLIV}	$\overline{\text{PSEN}}$ Low to Valid Instruction In		145		$3t_{\text{CLCL}}-45$	ns
t_{PXIX}	Input Instruction Hold after $\overline{\text{PSEN}}$	0		0		ns
t_{PXIZ}	Input Instruction Float after $\overline{\text{PSEN}}$		59		$t_{\text{CLCL}}-10$	ns
t_{PXAV}	$\overline{\text{PSEN}}$ to Address Valid	75		$t_{\text{CLCL}}-8$		ns
t_{AVIV}	Address to Valid Instruction In		312		$5t_{\text{CLCL}}-55$	ns
t_{PLAZ}	$\overline{\text{PSEN}}$ Low to Address Float		10		10	ns
t_{RLRH}	$\overline{\text{RD}}$ Pulse Width	400		$6t_{\text{CLCL}}-100$		ns
t_{WLWH}	$\overline{\text{WR}}$ Pulse Width	400		$6t_{\text{CLCL}}-100$		ns
t_{RLDV}	$\overline{\text{RD}}$ Low to Valid Data In		252		$5t_{\text{CLCL}}-90$	ns
t_{RHDX}	Data Hold after $\overline{\text{RD}}$	0		0		ns
t_{RHDZ}	Data Float after $\overline{\text{RD}}$		97		$2t_{\text{CLCL}}-28$	ns
t_{LLDV}	ALE Low to Valid Data In		517		$8t_{\text{CLCL}}-150$	ns
t_{AVDV}	Address to Valid Data In		585		$9t_{\text{CLCL}}-165$	ns
t_{LLWL}	ALE Low to $\overline{\text{RD}}$ or $\overline{\text{WR}}$ Low	200	300	$3t_{\text{CLCL}}-50$	$3t_{\text{CLCL}}+50$	ns
t_{AVWL}	Address to $\overline{\text{RD}}$ or $\overline{\text{WR}}$ Low	203		$4t_{\text{CLCL}}-75$		ns
t_{QVWX}	Data Valid to $\overline{\text{WR}}$ Transition	23		$t_{\text{CLCL}}-20$		ns
t_{QVWH}	Data Valid to $\overline{\text{WR}}$ High	433		$7t_{\text{CLCL}}-120$		ns
t_{WHQX}	Data Hold after $\overline{\text{WR}}$	33		$t_{\text{CLCL}}-20$		ns
t_{RLAZ}	$\overline{\text{RD}}$ Low to Address Float		0		0	ns
t_{WHLH}	$\overline{\text{RD}}$ or $\overline{\text{WR}}$ High to ALE High	43	123	$t_{\text{CLCL}}-20$	$t_{\text{CLCL}}+25$	ns

External Program Memory Read Cycle

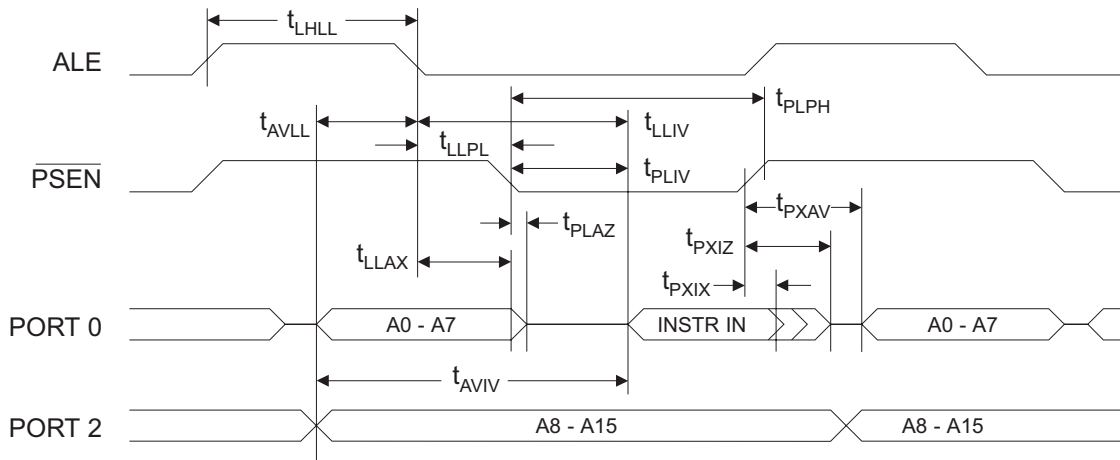

External Data Memory Read Cycle

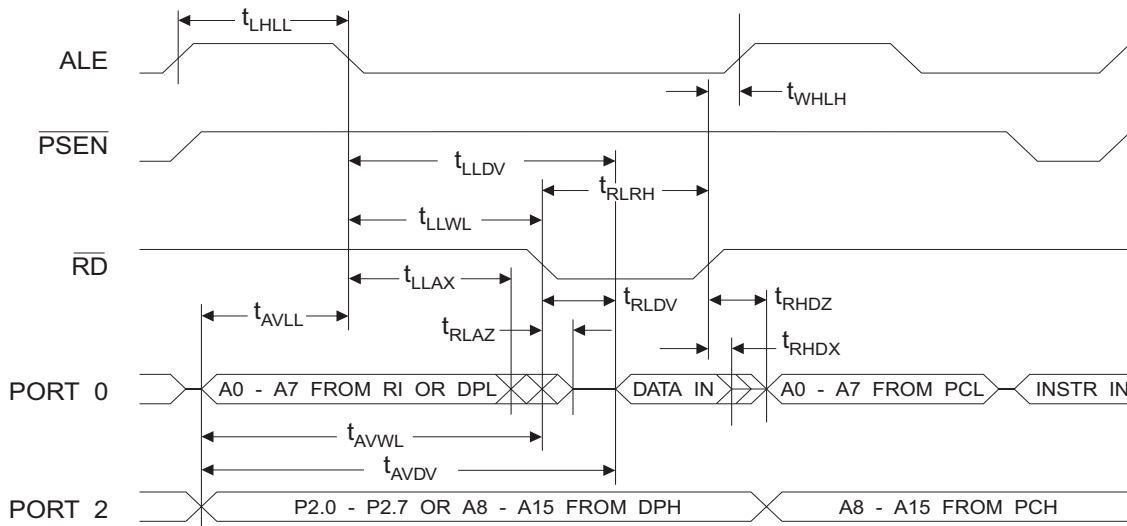

External Data Memory Write Cycle

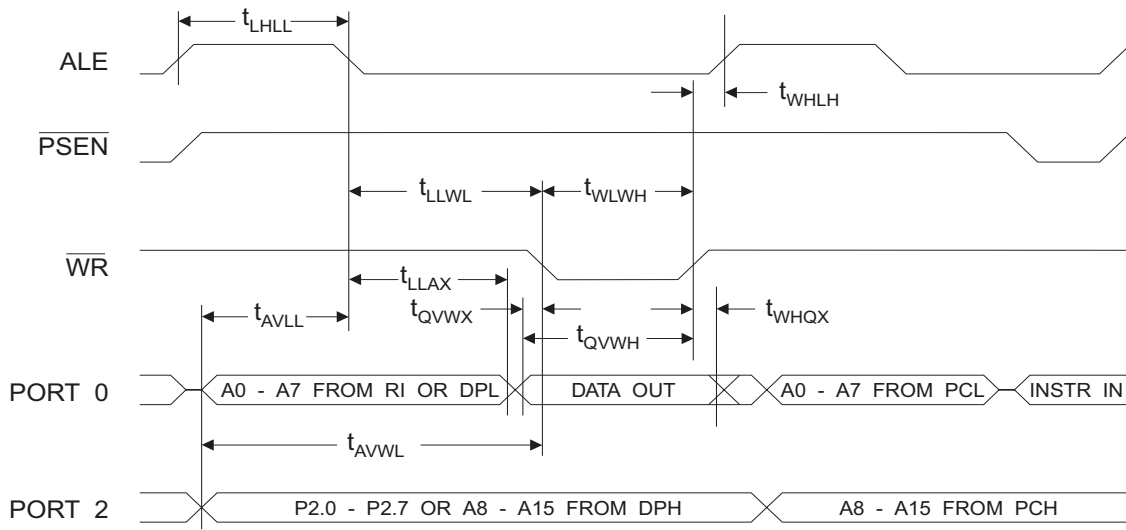

External Clock Drive Waveforms

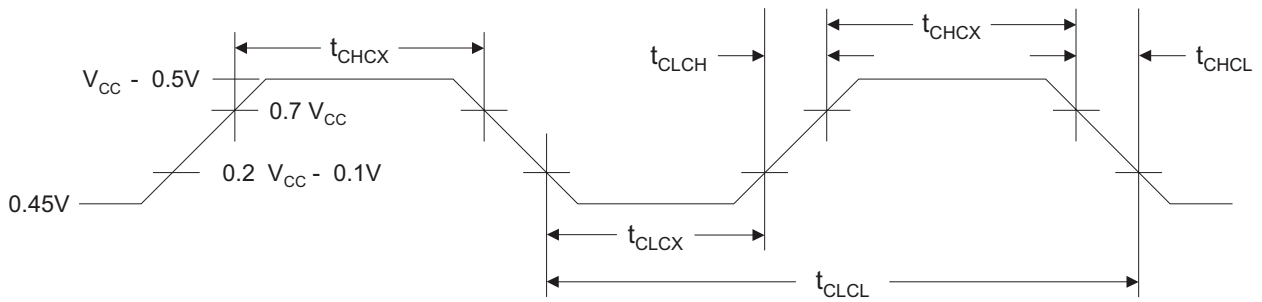

External Clock Drive

Symbol	Parameter	Min	Max	Units
$1/t_{CLCL}$	Oscillator Frequency	0	24	MHz
t_{CLCL}	Clock Period	41.6		ns
t_{CHCX}	High Time	15		ns
t_{CLCX}	Low Time	15		ns
t_{CLCH}	Rise Time		20	ns
t_{CHCL}	Fall Time		20	ns



Serial Port Timing: Shift Register Mode Test Conditions

($V_{CC} = 5.0\text{ V} \pm 20\%$; Load Capacitance = 80 pF)

Symbol	Parameter	12 MHz Osc		Variable Oscillator		Units
		Min	Max	Min	Max	
t_{XLXL}	Serial Port Clock Cycle Time	1.0		$12t_{CLCL}$		μs
t_{QVXH}	Output Data Setup to Clock Rising Edge	700		$10t_{CLCL}-133$		ns
t_{XHQX}	Output Data Hold after Clock Rising Edge	50		$2t_{CLCL}-117$		ns
t_{XHDX}	Input Data Hold after Clock Rising Edge	0		0		ns
t_{XHDV}	Clock Rising Edge to Input Data Valid		700		$10t_{CLCL}-133$	ns

Shift Register Mode Timing Waveforms

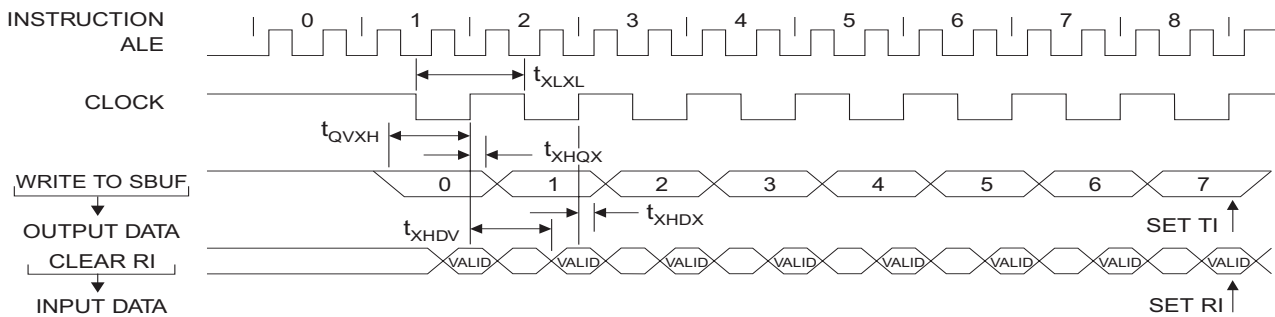

AC Testing Input/Output Waveforms⁽¹⁾

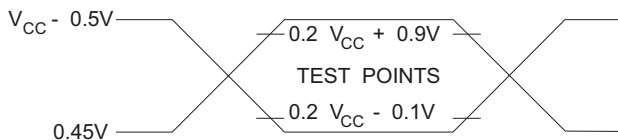

Note: 1. AC Inputs during testing are driven at $V_{CC} - 0.5\text{V}$ for a logic 1 and 0.45V for a logic 0. Timing measurements are made at V_{IH} min. for a logic 1 and V_{IL} max. for a logic 0.

Float Waveforms⁽¹⁾

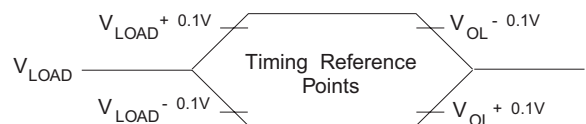

Note: 1. For timing purposes, a port pin is no longer floating when a 100 mV change from load voltage occurs. A port pin begins to float when 100 mV change from the loaded V_{OH}/V_{OL} level occurs.

Ordering Information

Speed (MHz)	Power Supply	Ordering Code	Package	Operation Range	
12	5V ±20%	AT89C51-12AC	44A	Commercial (0° C to 70° C)	
		AT89C51-12JC	44J		
		AT89C51-12PC	40P6		
		AT89C51-12QC	44Q		
			AT89C51-12AI	44A	Industrial (-40° C to 85° C)
			AT89C51-12JI	44J	
			AT89C51-12PI	40P6	
			AT89C51-12QI	44Q	
16	5V ±20%	AT89C51-16AC	44A	Commercial (0° C to 70° C)	
		AT89C51-16JC	44J		
		AT89C51-16PC	40P6		
		AT89C51-16QC	44Q		
			AT89C51-16AI	44A	Industrial (-40° C to 85° C)
			AT89C51-16JI	44J	
			AT89C51-16PI	40P6	
			AT89C51-16QI	44Q	
20	5V ±20%	AT89C51-20AC	44A	Commercial (0° C to 70° C)	
		AT89C51-20JC	44J		
		AT89C51-20PC	40P6		
		AT89C51-20QC	44Q		
			AT89C51-20AI	44A	Industrial (-40° C to 85° C)
			AT89C51-20JI	44J	
			AT89C51-20PI	40P6	
			AT89C51-20QI	44Q	
24	5V ±20%	AT89C51-24AC	44A	Commercial (0° C to 70° C)	
		AT89C51-24JC	44J		
		AT89C51-24PC	40P6		
		AT89C51-24QC	44Q		
			AT89C51-24AI	44A	Industrial (-40° C to 85° C)
			AT89C51-24JI	44J	
			AT89C51-24PI	40P6	
			AT89C51-24QI	44Q	

Package Type	
44A	44-lead, Thin Plastic Gull Wing Quad Flatpack (TQFP)
44J	44-lead, Plastic J-leaded Chip Carrier (PLCC)
40P6	40-lead, 0.600" Wide, Plastic Dual Inline Package (PDIP)
44Q	44-lead, Plastic Gull Wing Quad Flatpack (PQFP)

Packaging Information

44A, 44-lead, Thin (1.0 mm) Plastic Gull Wing Quad Flatpack (TQFP)
 Dimensions in Millimeters and (Inches)*
 JEDEC STANDARD MS-026 ACB

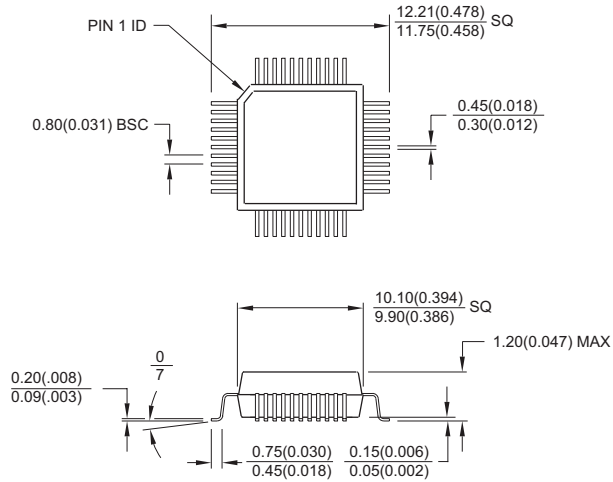

Controlling dimension: millimeters

44J, 44-lead, Plastic J-leaded Chip Carrier (PLCC)
 Dimensions in Inches and (Millimeters)
 JEDEC STANDARD MS-018 AC

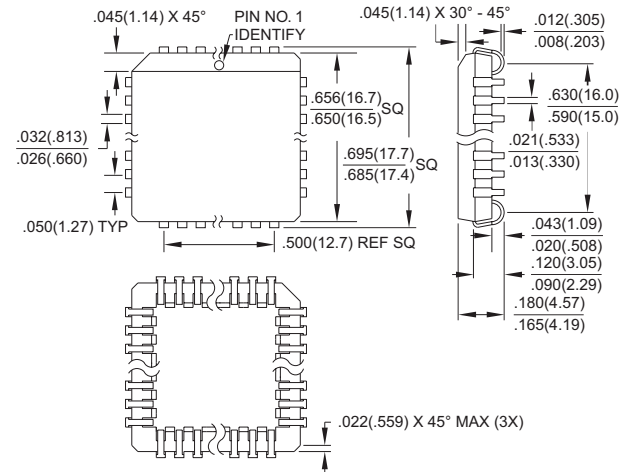

40P6, 40-lead, 0.600" Wide, Plastic Dual Inline Package (PDIP)
 Dimensions in Inches and (Millimeters)

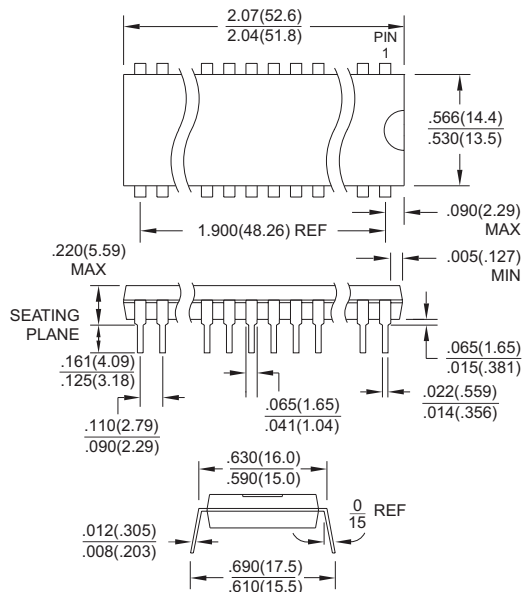

44Q, 44-lead, Plastic Quad Flat Package (PQFP)
 Dimensions in Millimeters and (Inches)*
 JEDEC STANDARD MS-022 AB

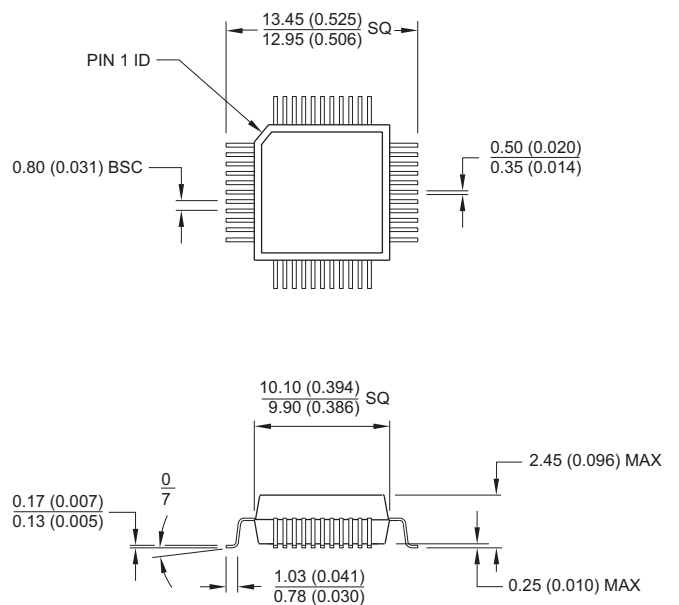

Controlling dimension: millimeters



Atmel Headquarters

Corporate Headquarters

2325 Orchard Parkway
San Jose, CA 95131
TEL (408) 441-0311
FAX (408) 487-2600

Europe

Atmel U.K., Ltd.
Coliseum Business Centre
Riverside Way
Camberley, Surrey GU15 3YL
England
TEL (44) 1276-686-677
FAX (44) 1276-686-697

Asia

Atmel Asia, Ltd.
Room 1219
Chinachem Golden Plaza
77 Mody Road Tsimhatsui
East Kowloon
Hong Kong
TEL (852) 2721-9778
FAX (852) 2722-1369

Japan

Atmel Japan K.K.
9F, Tonetsu Shinkawa Bldg.
1-24-8 Shinkawa
Chuo-ku, Tokyo 104-0033
Japan
TEL (81) 3-3523-3551
FAX (81) 3-3523-7581

Atmel Operations

Atmel Colorado Springs

1150 E. Cheyenne Mtn. Blvd.
Colorado Springs, CO 80906
TEL (719) 576-3300
FAX (719) 540-1759

Atmel Rousset

Zone Industrielle
13106 Rousset Cedex
France
TEL (33) 4-4253-6000
FAX (33) 4-4253-6001

Fax-on-Demand

North America:
1-(800) 292-8635
International:
1-(408) 441-0732

e-mail

literature@atmel.com

Web Site

<http://www.atmel.com>

BBS

1-(408) 436-4309

© Atmel Corporation 2000.

Atmel Corporation makes no warranty for the use of its products, other than those expressly contained in the Company's standard warranty which is detailed in Atmel's Terms and Conditions located on the Company's web site. The Company assumes no responsibility for any errors which may appear in this document, reserves the right to change devices or specifications detailed herein at any time without notice, and does not make any commitment to update the information contained herein. No licenses to patents or other intellectual property of Atmel are granted by the Company in connection with the sale of Atmel products, expressly or by implication. Atmel's products are not authorized for use as critical components in life support devices or systems.

Marks bearing ® and/or ™ are registered trademarks and trademarks of Atmel Corporation.

Terms and product names in this document may be trademarks of others.



Printed on recycled paper.

0265G-02/00/xM